



Fast Food Teknik a/s

Users Manual

Turbomatic contact grill GL 9000 series



Version 2.5 – JUNI 2021

Content of this manual

Content of this manual	3
1. Introduction	4
2. Generally	4
2.1. Manufacturer	4
2.2. Machine plate	4
Machine plate is placed in the back on the left side.	4
3. Overview and application	5
3.1. General description	5
3.2. The contact grill purpose and intended use	5
3.3. Warning on foreseeable misuse	5
3.4. Technical specifications and consumption	5
3.5. Placement of the contact grill	6
4. Safety and residual risks	6
4.1. Safety precautions to be taken by the user	6
4.1.1. Personal safety equipment.....	6
4.2. Residual risks	6
5. Operation	7
5.1. Quick-guide	7
5.2. Programming.....	7
5.3. Locking display.....	9
5.4. Stop.....	9
5.5. Emergency stop	9
5.5.1. Restart after emergency stop	9
5.6. Adjustment	10
5.7. Frying	10
6. Transport and installation	11
6.1. Transport.....	11
6.2. Installation.....	11
6.3. Demands to the installation place	11
6.4. Connection	11
7. Maintenance, fault-finding and repair	12
7.1. Cleaning and order	12
7.2. Preventive maintenance	12
7.2.1. Fault finding.....	13
7.3. Repair.....	13
7.3.1. Specifications on spare parts	14
8. End of use	22
8.1. Destruction	22
22	
9. Annex	22
9.1. Labels, symbols and pictograms	22
9.2. EC Declaration of Conformity	23
9.4. Wiring diagrams	24

1. Introduction

Original manual

This manual is FKI Fast Food Teknik A/S translation to the original instructions for Turbomatic contact grill, hereinafter called the contact grill.

Purpose

The purpose of this manual is to ensure proper installation, use, handling and maintenance of contact grill.

Accessibility

The instructions must be kept in a known place for staff where it is easily accessible to operators and maintenance personnel.

Knowledge

It is the employer's (owner of the contact grill) obligation to ensure that all who serve, maintain or repair the contact grill, read the instructions, at least those parts of it that are relevant to their work.

Additionally, all who serve, maintain or repair the contact grill, must themselves seek information in the instructions.

2. Generally

2.1. Manufacturer

The contact grill is manufactured by

Company name: FKI Fast Food Teknik A/S
Adress: Byghøjvej 5, Verringe
5690 Tommerup

Name of the contact grill:

The full name of the contact grill is Turbomatic GL 90xx.

2.2. Machine plate

Machine plate is placed in the back on the left side

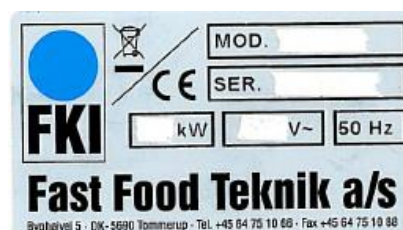

3. Overview and application

3.1. General description

Turbomatic contact grill has been designed for simultaneous cooking on both sides, since the machine have an upper and a lower fry pan. The contact grill is made of stainless steel with an easy to clean surface.

3.2. The contact grill purpose and intended use

The contact grill is for roasting meat with a uniform thickness, also directly from the frozen state.

3.3. Warning on foreseeable misuse

Do not use the contact grill for any purpose than frying meat products.

3.4. Technical specifications and consumption

Dimensions

	GL 9001	GL 9002	GL 9003	GL 9010
Dimension W x D x H [mm]	400 x 630 x 480	600 x 630 x 480	400 x 630 x 480	490 x 730 x 480
Weight	62 kg	85 kg	65 kg	95 kg

Note the height is set in the closed state (represented by frying). When open, an additional 200 mm space, so the maximum height is 680 mm.

Electricity

The contact grill must be earth connected and RCD through connection socket.

Connection power: 3 x 400 V AC (3L + N + EG)

Connection frequency: 50/60 Hz

	Connection power	Absorbed power	Absorbed current	Min. Fuse in installation
GL 9001	400 V	8,8 kW	18,5 A	20 A
GL 9002	400 V	13,7 kW	19,2 A	20 A
GL 9003	400 V	9,8 kW	15,2 A	20 A
GL 9010	400 V	11,1 kW	16 A	16 A

Noise

Airborne noise coming from the contact grill:

Measured sound pressure level dB(A): < 70.

3.5. Placement of the contact grill

The contact grill must be set up on a table or the like in an appropriate working height.

Operation is done from the front of the contact grill.

For the sake of ventilation, allow free passage of air under and behind the machine.

The contact grill must be placed under hoods or other suction of cooking smells.

4. Safety and residual risks

4.1. Safety precautions to be taken by the user

4.1.1. Personal safety equipment

It is recommended to use gloves during the operation of the grill since there are several hot surfaces on the contact grill.

4.2. Residual risks



The surfaces, especially upper and lower fry pan, but also the housing of the upper fry pan is very hot. Therefore take care not to touch these during operation of the contact grill.

5. Operation

5.1. Quick-guide

The main switch mounted at the rear turns on the contact grill.

The contact grill will move the upper pan(s) to opened position and is now in the Off mode. The display shows a small dot at bottom's right corner of the display, indicating that there is power on the contact grill.



The contact grill is operated by pressing ON, and upper frying pan will close. The contact grill goes into standby mode and begin heating to the preset standby temperature. When this temperature is reached, the contact grill is ready for use.

Switch from standby to operation mode is done by pressing the + / Normal button. Then the upper fry pan opens, and the grill is ready for use, if the standby temperature and normal temperature are equal programmed.



Place the meat on the bottom pan and press one of the program buttons (1-3). The upper will close and the meat will fry on both sides in the pre-set time, as the display counts down to 0, after which the upper pan opens, while a sound signal indicates that cooking is completed.

If the contact grill is not used for a long time, it is recommended to put it on hold. This is done by pressing the - / standby button and the upper pan will be closed to save energy.

5.2. Programming

All programming can only be done when the contact grill are in standby mode.

Programming of frying times:

1. Press [2] and hold for more than 10 sec. upper display will now show -2 –
2. Press (1-3) for the program that is to be changed. The display now showing the setting value (in seconds) for the program.
3. Value is changed by pushing [+] or [-].
4. The program will return to the menu after 5 seconds. Wait until this happens and changes are saved.
5. To leave the menu press [Reset].

Programming of temperatures:

1. Press [3] and hold for more than 10 sec. upper display will now show -3 –
2. Press button [1] to show the operation set temperature for the upper pan. Change the setting by pushing + or -.
3. Press button [2] to show the operation set temperature for the lower pan. Change the setting by pushing + or -.
4. Press button [3] to show the standby set temperature for both pans. Change the setting by pushing + or -. Notice! Standby temperature shall be set close to the operation temperature to avoid waiting for the temperature to rise when going from stand by to normal.
5. The program will return to the menu after 5 seconds. Wait until this happens and changes are saved.
6. To leave the menu press [Reset].

Factory settings:

Standby temp.	225 °C
Normal temp. upper pan	225 °C
Normal temp. lower pan	225 °C
Program 1	130 sec.
Program 2	130 sec.
Program 3	130 sec.

Encoding the volume:

- Press [3] and hold for more than 6 sec. The programming menu 3 will appear in the display.
- Press [on] to change the Standby sound.
- Press [+ and -] to change the volume.
- The program returns to menu after 5 seconds, and the modified time saved.
- To exit the menu, press RESET.

5.3. Locking display

The display shows as well in standby as in normal mode the temperature of the lower pan. Showing the temperature of the upper pan will occur shortly when turning from standby to normal operation.

During frying, there are major temperature fluctuations, which is quite normal. To let the user not need to become confused about this, the view of the temperature is locked so that temperatures above the preset appears as the preset. This means that when temperature exceeds the preset temperature, this excess will not be displayed.

The lock can be revoked by in the stand-by mode to keep the ON button pressed for min. 10 sec. The next time the contact grill off at OFF and switching ON will lock again be active.

Operating

The main switch on the backside of the contact grill turns on the Power to the contact grill.

By pushing the ON button, the contact grill is set to standby mode.

By pushing the +/Normal button the contact grill is set to operation mode.

5.4. Stop

The contact grill is stopped by pressing OFF, and the upper pan opens and all functions are switched off.

If you wish to shut off the contact grill with the pan(s) down, turn to standby mode and thereafter turn the main switch to OFF.

Interrupting a program (countdown of the cooking time) can be stopped by pressing the RESET. Subsequently, the upper pan open and frying on the top stop. Note however that frying on the underside is ongoing.

To shut off power to the contact grill turn the main switch on the back side to OFF.

5.5. Emergency stop

The upper pan can be stopped during movement by turning the main switch to OFF

5.5.1. Restart efter emergency stop

When the main switch is turned to ON, the contact grill will go in start up position with open pans.

5.6. Adjustment

The distance between the upper and lower pan should be adjusted to suit the thickness of the meat.

The distance is continuously adjustable between 5 and 25 mm, by turning the adjustment knob on the top arm on the upper pan.

Turning the knob clockwise will increase the distance and counterclockwise reduces the distance.

5.7. Frying

By frying, the meat is placed as close as possible in the middle of the upper pan. If there is more than one piece of meat it is placed "symmetrically" around the centre. This is to avoid that the upper pan "flips" and thus do not get full contact with the meat.



6. Transport and installation

6.1. Transport

The contact grill should only be transported when fastened to a pallet or similar.

6.2. Installation

The contact grill is to be installed on flat ground, counter top or the like. The legs shall be adjusted so that the contact grill is higher in the rear than in front, so excess fat can drain to the fat drain.

6.3. Demands to the installation place

The surface of the contact grill must have sufficient capacity. See the technical data section. 3.4.

In particular, if the counter top is hanging on the wall be aware that this is firmly attached and that the wall is suitable for fixing of heavy loads.

Note that there must be free passage of air behind the machine, underneath the machine and in front of the machine. Do not place any objects, cloths, gloves or the like that can prevent a free circulation of air.

6.4. Connection

Only authorized personnel shall connect the contact grill. Plug are not part of the delivery but can be ordered separately.

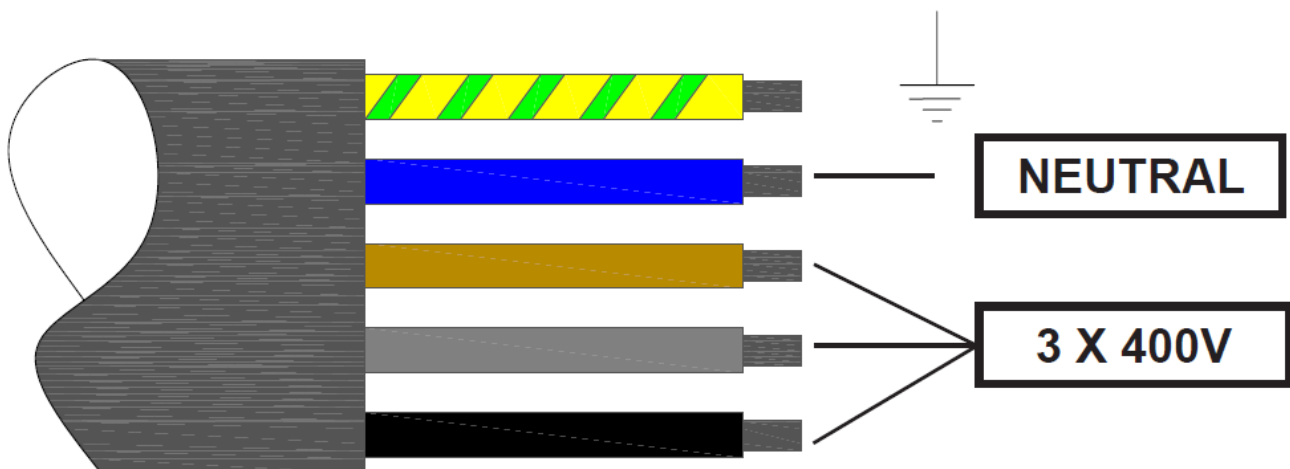

Be aware that the installation is done properly with adequate fuse and be-protection against fault current and grounding.

7. Maintenance, fault-finding and repair

7.1. Cleaning and order

It is important that the fat drawer is regularly emptied of excess fat, as this will overflow.

Use the provided spatula to periodically scrape excess grease into the grease drain. If possible, use paper to dry pans of, like after every 5th-10th frying.

Daily cleaning is performed when the contact grill has cooled of. Dry cabinets with a damp cloth with a mild detergent. Wipe dry with a dry cloth or paper.

Grease drawer is emptied and cleaned in hot water with a mild detergent if necessary. Or in the dishwasher.

Once a day must pans thoroughly be cleaned so that all food residues are removed. If possible, use a stainless steel sponge with mild detergent. The pan must be completely cleaned and appear "blank". Wipe dry with clean cloth or paper.

If Teflon sheet is used in the pans, clean them with a damp cloth with a mild cleaning agent. We recommend using Teflon sheet (supplied) as it prevents burn-in, and facilitate subsequent cleaning.

7.2. Preventive maintenannce

Replacing the Teflon sheet on the upper pan is performed as needed. Always do this when the contact grill is cold.

The teflon sheet is mounted with adhesive tape. Remove the foil from the pan on both sides.

Possibly residual adhesive from the tape, can be removed with a scraper. Heating of the machine to about 50°C can ease that process. Use a damp cloth or steel sponge with detergent to completely remove glue residue. Remember to turn off the machine before it becomes too hot.

When the contact grill again cools down, the new film is mounted. Remove the tape on one side and place the teflon sheet on the edge of the upper pan cabinet. Remove the tape on the other side, and set the adhesive film in place.

7.2.1. Fault finding

Problem	Cause / Possible solution
Display shows 1	Sensor on lower heat element is short circuited – Change the sensor
Display shows 2	Sensor on lower heat element is disconnected – Check connection
Display shows 3	Sensor on upper heat element is short circuited – Change the sensor
Display shows 4	Sensor on upper heat element is disconnected – Check connection
The are no light in the display	Make sure the power cord is plugged in and that any safety switch is turned on and the main power switch on the back of the machine is ON.
Still no light in the display	Check the fuse on the back of the machine
Still no light in the display	Check the power switch on the back of the machine if there is live voltage on all phases.
There is no light in one display (other is OK)	Check the power switch on the back of the machine if there is live voltage on all phases.
Still no light in one display (other is OK)	Check the TRAFO for the PCB
Still no light in one display (other is OK)	Check the fuse on the PCB
Still no light in one display (other is OK)	Try to connect a new keypad, to check if it's the keyboard that is defective. The plug must be installed correctly on the PCB, the shiny side must face the pan
Still no light in one display (other is OK)	Try to connect a new PCB in order to check if the PCB is defective. If you change the PCB it must be checked that the new PCB is programmed correctly with Temperatures and times, check the operating instructions.
The pan(s) are not functioning (open/close)	Check the ring trafo for actuators (motors).
The pan(s) are not functioning (open/close)	Check rectifyer for actuators (motors).
One of the pans are still not functioning (other is OK)	Check wiring from PCB to actuator. (Measuring 1 and 2 on the rear terminal blocks must show 24V DC)
One of the pans are still not functioning (other is OK)	Change actuator
There are no heat in one or more heat elements	Check solid state relay, to the heat element that is not heating up
There are no heat in one or more heat elements	Check the heat element by measuring directly on the element

7.3. Repair

Authorized service personnel with knowledge of electrical appliances should always perform repair.

7.3.1. Specifications on spare parts

GL 9001

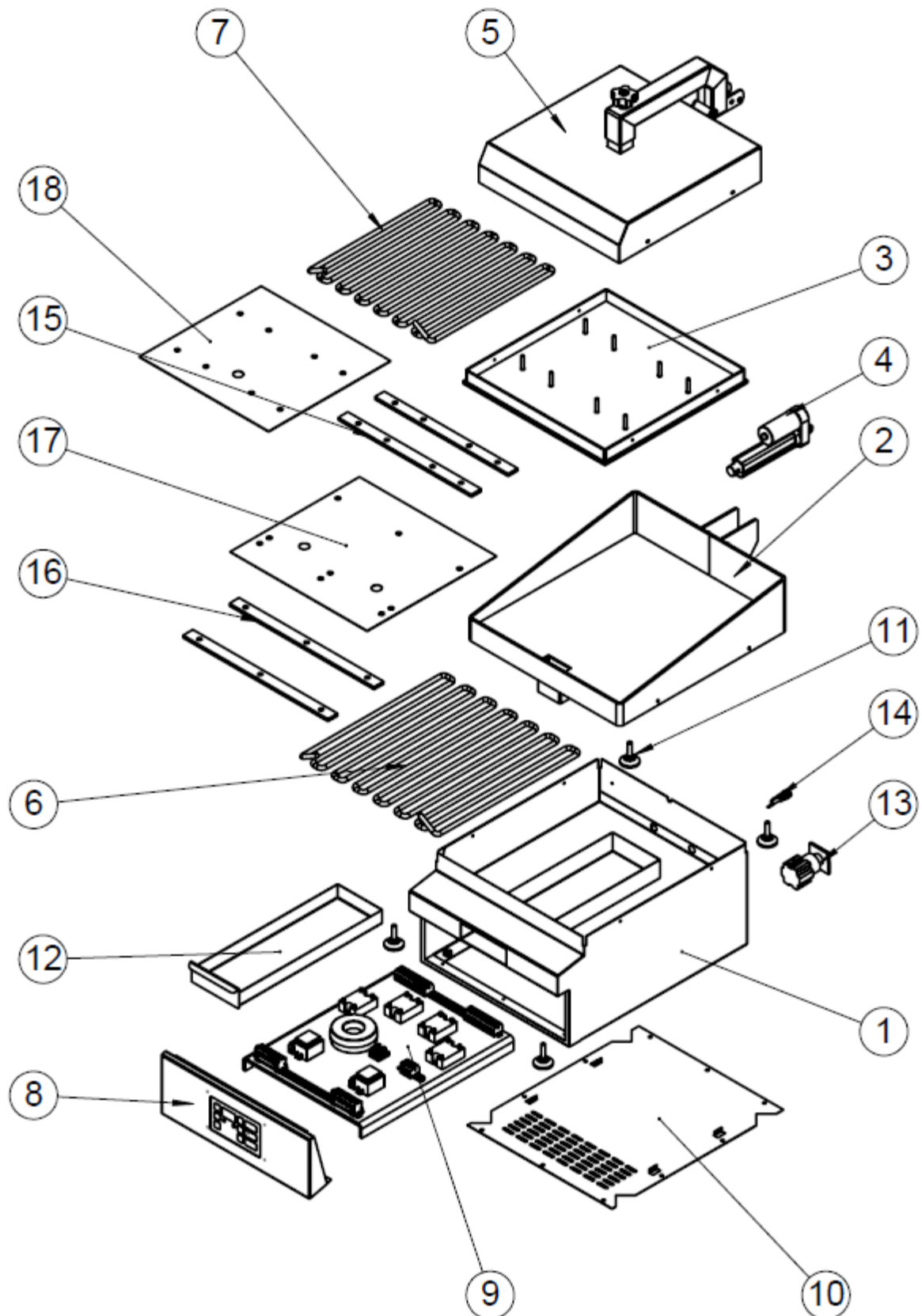

Pos.	Part no.	Pcs.	Description
1	83-10314	1	Bottom cabinet GL 9001
2	83-10315	1	Pan GL 9001, lower
3	83-10279	1	Pan upper large
4	83-10022	1	Actuator MLA-2
5	83-10237	1	Top cabinet large incl. arm
6	83-09322	1	Heatelement lower 4,7 kW 400V
7	83-09320	1	Heatelement upper 4,1 kW 400V
8	83-10323	1	Frontpanel incl. PCB and key.pad
9	83-20103	1	Electrical components – see wiring diagram
10	83-09975	1	Bottom plate GL 9001/3
11	82-06510	4	Leg M8 adjustable
12	83-09980	1	Fat drawer
13	84-00067	1	Switch 4-polet CA25 32 A
13a	84-00292	1	Handle for switch
14	84-00290	1	Fuse holder
14a	72-00133	1	Fuse 5A
15	83-09313	2	Tension piece large upper
16	83-09312	2	Tension piece lower
17	83-09119	1	Cover plate upper large
18	83-10194	1	Cover plate lower

GL 9002

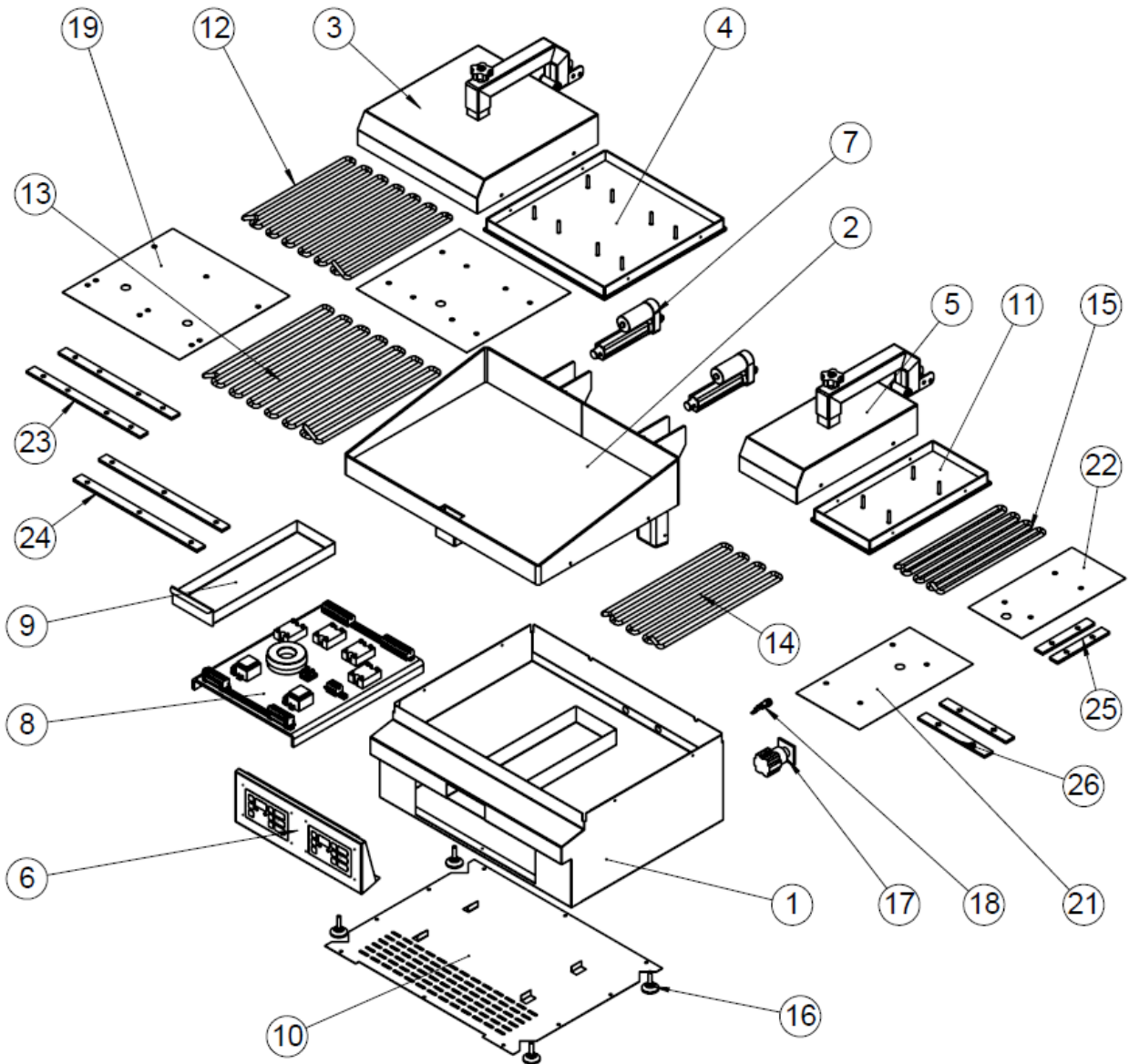

Pos.	Part no.	Pcs.	Description
1	83-10292	1	Bottom cabinet GL 9002
2	83-10293	1	Pan GL 9002 lower
3	83-10237	1	Top cabinet large incl. arm
4	83-10279	1	Pan upper large
5	83-10325	1	Top cabinet small incl. arm
6	83-10324	1	Frontpanel double incl. PCB and key-pad

Pos.	Part no.	Pcs.	Description
7	83-10022	2	Actuator MLA-2
8	83-20104	1	Electrical components – see wiring diagram
9	83-09980	1	Fat drawer
10	83-10288	1	Bottom plaet 600 mm
11	83-09981	1	Pan small
12	83-09320	1	Heat element upper 4,1 kW 400V
13	83-09322	1	Heat element lower 4,7 kW 400V
14	83-09323	1	Heat element lower 2,6 kW 400V
15	83-09323	1	Heatelement upper 2,3 kW 400V
16	82-06510	4	Leg M8 adjustable
17	84-00067	1	Switch 4-polet CA 25 32A (400V)
17a	84-00292	1	Handle for switch type CA
18	84-00290	1	Fuse holder
18a	72-00133	1	Fuse 5A
19	83-09119	1	Cover plate lower large
20	83-10194	1	Cover plate upper large
21	83-09120	1	Cover plate lower small
22	83-10195	1	Cover plate upper small
23	83-09313	2	Tension piece upper large
24	83-09312	2	Tension piece lower large
25	83-09329	2	Tension piece upper small
26	83-09135	2	Tnsion piece lower small

GL 9003

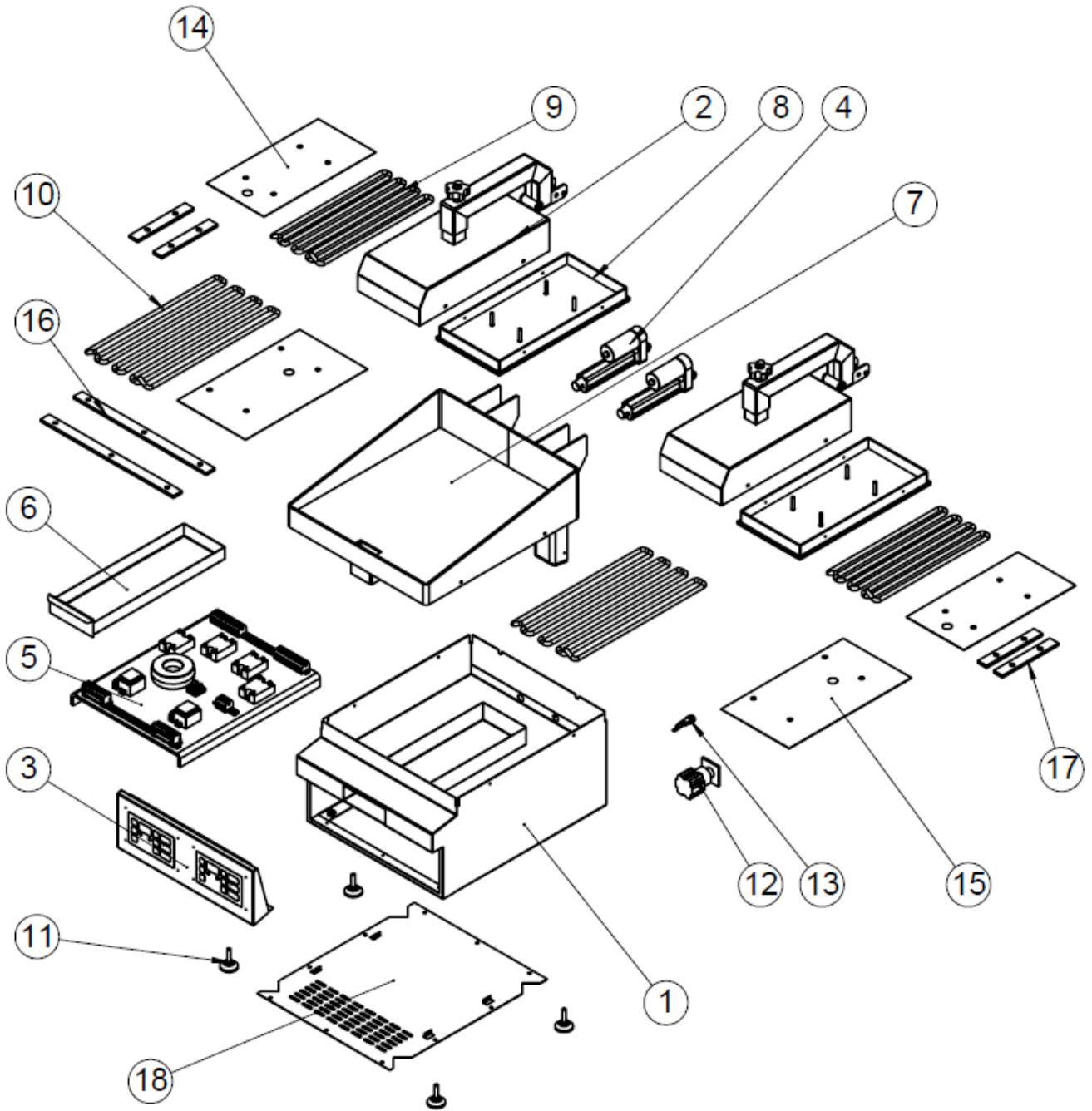

Pos.	Part no.	Pcs.	Description
1	83-09984	1	Bottom cabinet GL 9003
2	83-10325	2	Top cabinet small incl. arm
3	83-10324	1	Frontpanel double incl. PCB and key-pad
4	83-10022	2	Actuator MLA-2
5	83-20105	1	Electrical components – see wiring diagram
6	83-09980	1	Fat drawer
7	83-09985	1	Pan GL 9003 lower
8	83-09320	2	Pan upper small
9	83-09321	2	Heat element upper 2,3 kW 400V
10	83-09323	2	Heat element lower 2,6 kW 400V
11	82-06510	4	Leg M8 adjustable
12	84-00067	1	Switch 4-polet CA25 32 A
12a	84-00292	1	Handle for switch
13	84-00290	1	Fuse holder
13a	72-00133	1	Fuse 5A
14	83-10195	2	Cover plate upper small
15	83-09120	2	Cover plate lower small
16	83-09312	2	Tension piece lower
17	83-09329	4	Tension piece upper small
18	83-09975	1	Bottom plate GL 9001/3

GL 9010

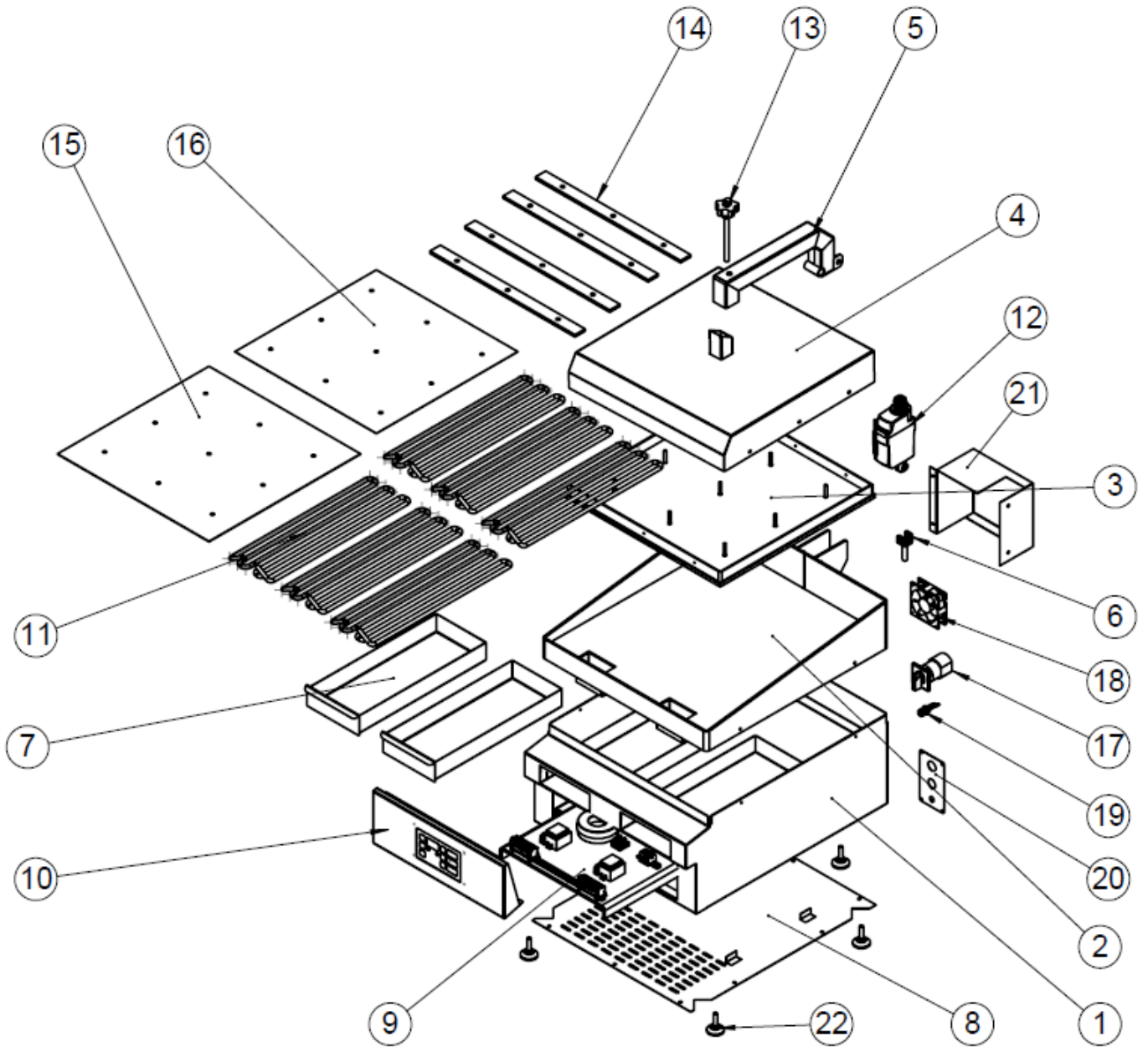

Pos.	Part no.	Pcs.	Description
1	83-10332	1	Bottom cabinet GL 9010
2	83-10330	1	Pan GL 9010
3	83-10335	1	Top pan GL 9010
4	83-10337	1	Top cabinet GL 9010
5	83-10346	1	Arm GL 9010
6	83-10352	1	Adjusting bracket for actuator GL 9010
7	83-10353	2	Fat drawer GL 9010
8	83-10326	1	Bottom plate GL 9010
9	83-20103	1	Electrical components – see wiring diagram
10	83-10323	1	Frontpanel incl. PCB and key-pad
11	83-10333	6	Heat element 1,85 kW 400V
12	83-10325	1	Actuator LA 23
13	83-10096	1	Adjustingbolt for pan
14	83-10336	4	Tension piece GL 9010
15	83-10355	1	Cover plate lower GL 9010
16	83-10354	1	Cover plate upper GL 9010
17	84-00068	1	Seitch 4-pole CA20 25A
18	83-00086	1	Cooling fan80x80x25 24V DC
19	84-00290	1	Fuse holder
19a	72-00133	1	Fuse 5A
20	83-10099	1	Mounting plate for 25A switch
21	83-10317	1	Cover back
22	82-06510	4	Leg M8 adjustable

8. End of use

8.1. Destruction



The contact grill is marked with the above recycling symbol. (EC Directive 2002/96/EC) and must be disposed of in accordance with your country order.

This means that when the product becomes obsolete, you should dispose of it after the local municipality's rules, for example in unsorted waste stream.

9. Annex

9.1. Labels, symbols and pictograms

The hamburger machine is marked with the following symbols and pictograms:



Recycling symbol in accordance to EC (see part 6)



Hot surface – use gloves.

9.2. EC Declaration of Conformity



EU DoC ID: FKI 001
Verninge, 29. januar 2021

EU DECLARATION OF CONFORMITY

We FKI Fast Food Teknik a/s declares under our sole responsibility that the product Turbomatic with

Model no.:

GL 9001, GL 9002, GL 9003 and GL 9010

are in conformity with the following directive(s), standard(s) or other normative document(s), provided that the products are used in accordance with our instructions.

Directives	Standards
Machine Directive 2006/42/EC	EN/ISO 12100:2010 EN 60335-1:2012 + AC:2014 + A11:2014 EN 60335-2-38:2003 + A1:2008 EN/IEC 60204-1:2005 (partly) EN/IEC 60204-1:2005/A1:2008 (partly)
Electromagnetic Compatibility Directive 2014/30/EU	EN 55014-1:2006 + A1:2009 + A2:2011 EN 55014-2:1997 + A1:2001 + A2:2008
WEEE Directive 2012/19/EU RoHS Directive 2011/65/EU	
Regulations	Standards
Food Contact Materials 1935/2004 Good Manufacturing Practice 2023/2006	N/A

Date 29/1-2021	Issued by  Søren Poulsen - Managing Director
-------------------	--

FKI Fast Food Teknik a/s only vouches for the correctness of the English version of this declaration. In the event of the declaration being translated into any other language, the translator concerned shall be liable for the correctness of the translation.

Byghøjvej 5 · Verninge · DK-5690 Tommerup
Tel. +45 64 75 10 66 · Fax +45 64 75 10 88 · CVR no. 1472 8287 · www.fki.dk

9.3. Wiring diagrams

GL 9001 400V

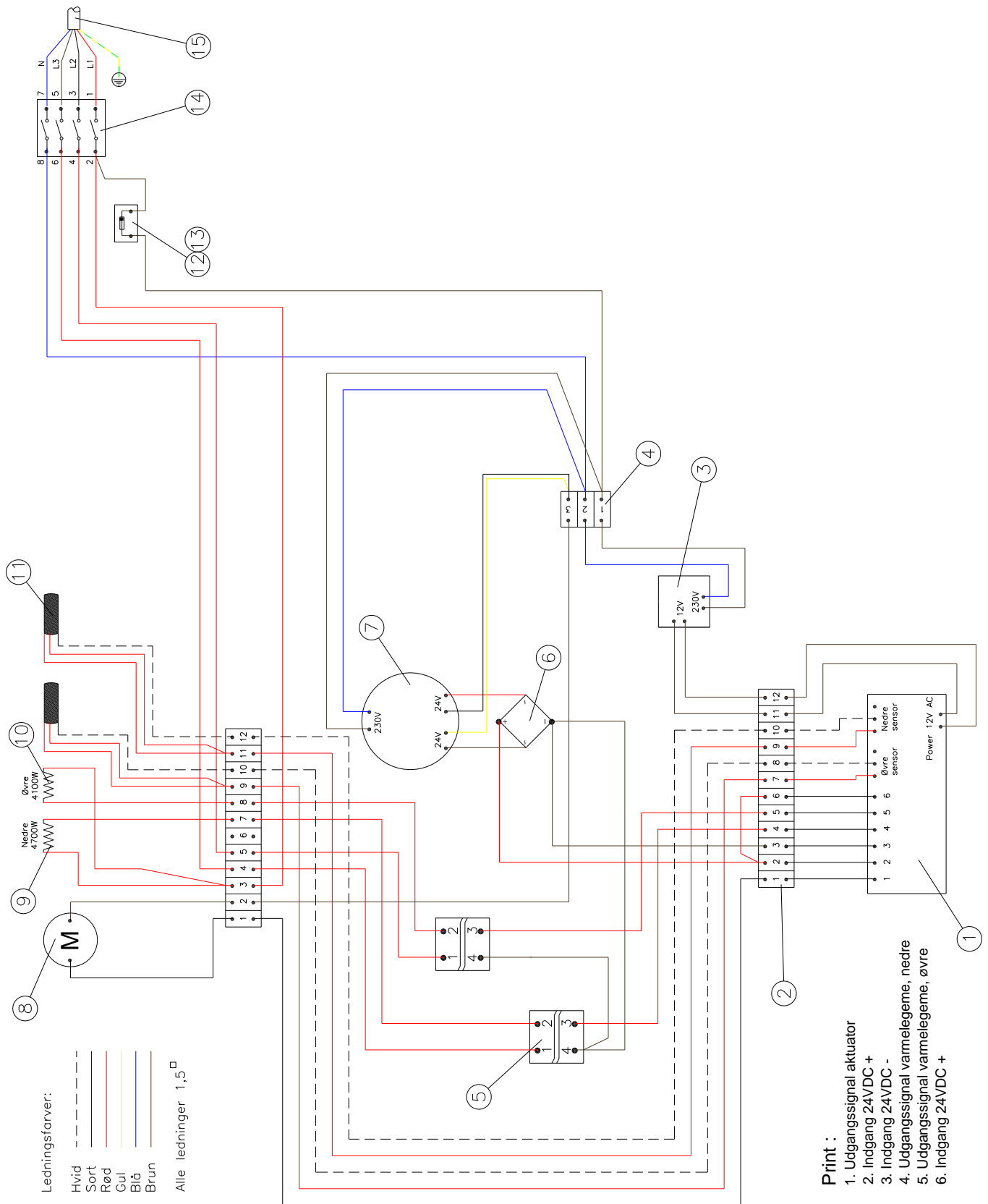

Pos.	Part no.	Pcs.	Description
1	83-10039	1	PCB GL90 serie
2	83-07681	2	Connection block 12-pole
3	83-09056	1	Transformer 230V – 12V 3VA
4	83-07952	1	Connection block 3-pole
5	83-10316	2	Relay SSR 20-265A
6	83-07563	1	Rectifyer
7	84-00294	1	Ringtransformer 230V – 2x24V 80VA
8	83-10022	1	Actuator MLA-2
9	83-09322	1	Heat element lower 4,7 kW 400V
10	83-09320	1	Heat element upper 4,1 kW 400V
11	83-09057	1	Sensor PT100 upper
11a	83-09998	1	Sensor PT100 lower
12	84-00290	1	Fuse holder
13	84-00289	1	Fuse 2A
14	84-00067	1	Switch 4-polet CA25 32A
15	72-03674	1	Connection cabel 5 x 2,5 mm ²

GL 9002 400V

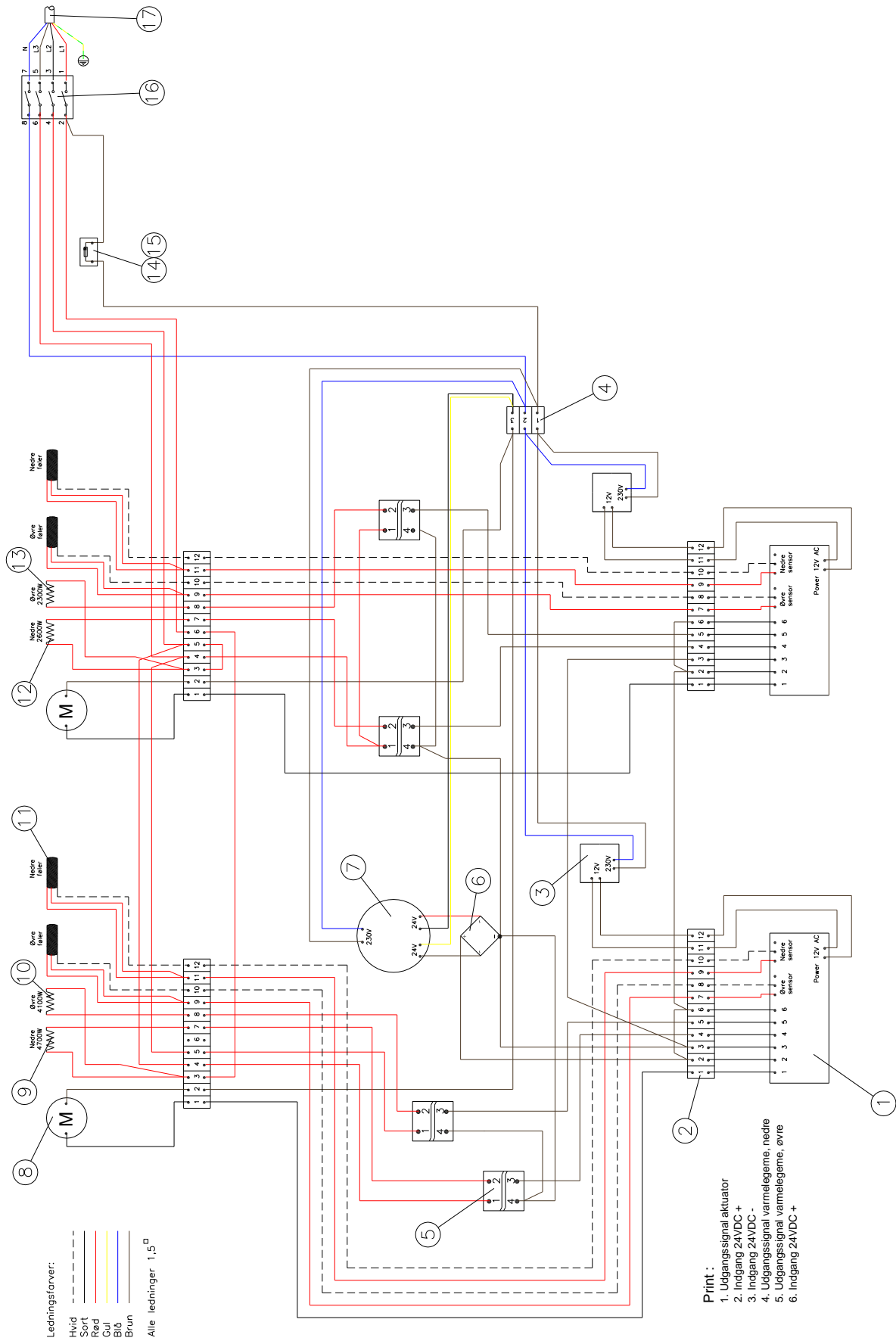

Ledningsforer:
 Hvid
 Sort
 Rød
 Gul
 Blå
 Brun
 Alle ledninger 1,5²

- Print :
1. Udgangssignal aktuator
 2. Indgang 24VDC +
 3. Indgang 24VDC -
 4. Udgangssignal varmelegeme, nedre
 5. Udgangssignal varmelegeme, øvre
 6. Indgang 24VDC +

Pos.	Part no.	Pcs.	Description
1	83-10039	2	PCB GL90 serie
2	83-07681	4	Connection block 12-pole
3	83-09056	1	Transformer 230V – 12V 3VA
4	83-07952	1	Connection block 3-pole
5	83-10316	4	Relay SSR 20-265A
6	83-07563	1	Rectifyer
7	84-00295	1	Ringtransformer 230V – 2x24V 80VA
8	83-10022	2	Actuator MLA-2
9	83-09322	1	Heat element lower 4,7 kW 400V
10	83-09320	1	Heat element upper 4,1 kW 400V
11	83-09057	1	Sensor PT100 upper
11a	83-09998	1	Sensor PT100 lower
12	83-09323	1	Heat element lower 2,6 kW 400V
13	83-09321	1	Heat element upper 2,3 kW 400V
14	84-00290	1	Fuse holder
15	84-00289	1	Fuse 2A
16	84-00067	1	Switch 4-polet CA25 32A
17	72-03674	1	Connection cabel 5 x 2,5 mm ²

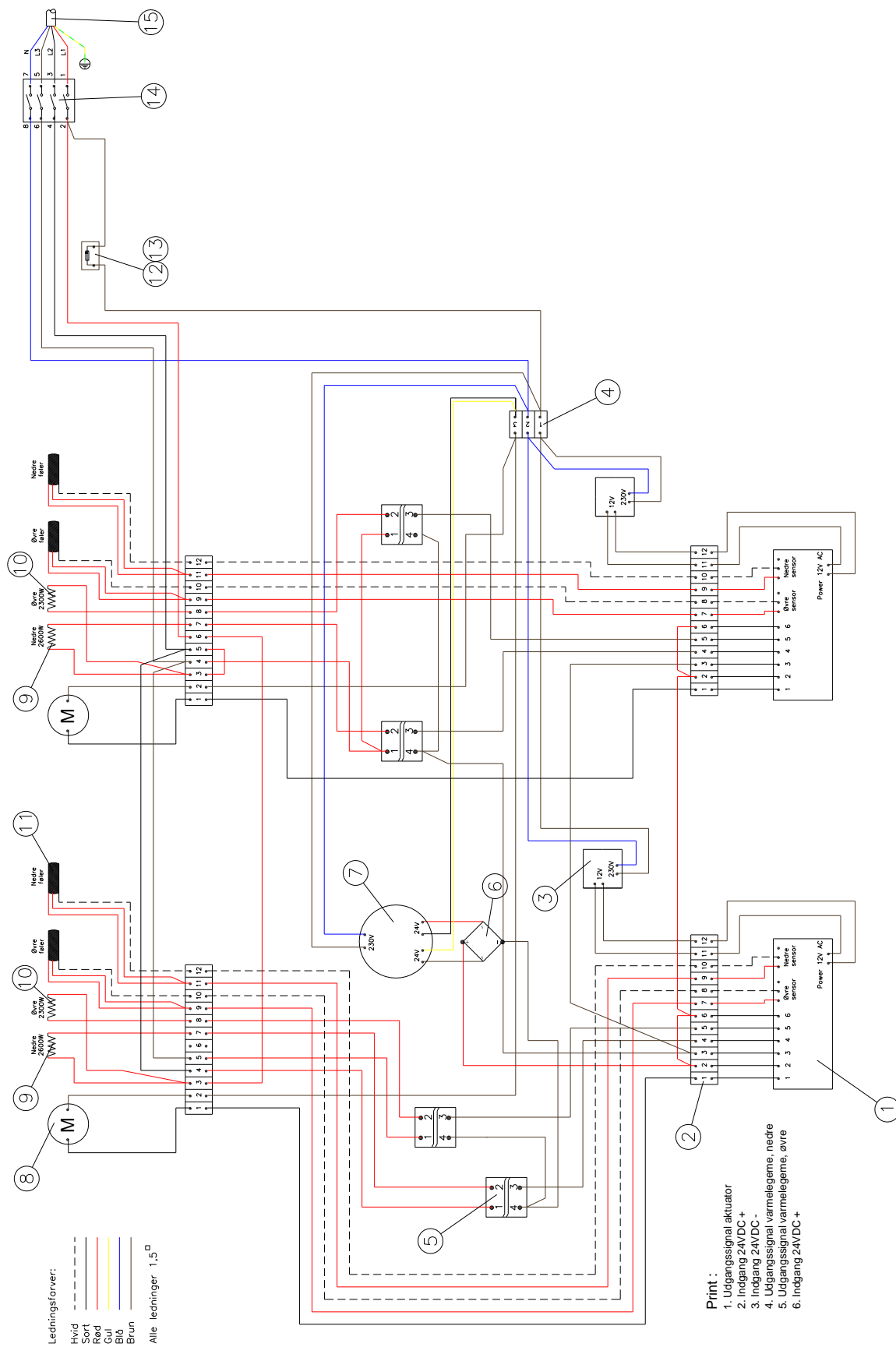

Pos.	Part no.	Pcs.	Description
1	83-10039	2	PCB GL90 serie
2	83-07681	4	Connection block 12-pole
3	83-09056	1	Transformer 230V – 12V 3VA
4	83-07952	1	Connection block 3-pole
5	83-10316	4	Relay SSR 20-265A
6	83-07563	1	Rectifyer
7	84-00295	1	Ringtransformer 230V – 2x24V 80VA
8	83-10022	2	Actuator MLA-2
9	83-09323	1	Heat element lower 2,6 kW 400V
10	83-09321	1	Heat element upper 2,3 kW 400V
11	83-09057	1	Sensor PT100 upper
11a	83-09998	1	Sensor PT100 lower
12	84-00290	1	Fuse holder
13	84-00289	1	Fuse 2A
14	84-00067	1	Switch 4-polet CA25 32A
15	72-03674	1	Connection cabel 5 x 2,5 mm ²

GL 9010 400V

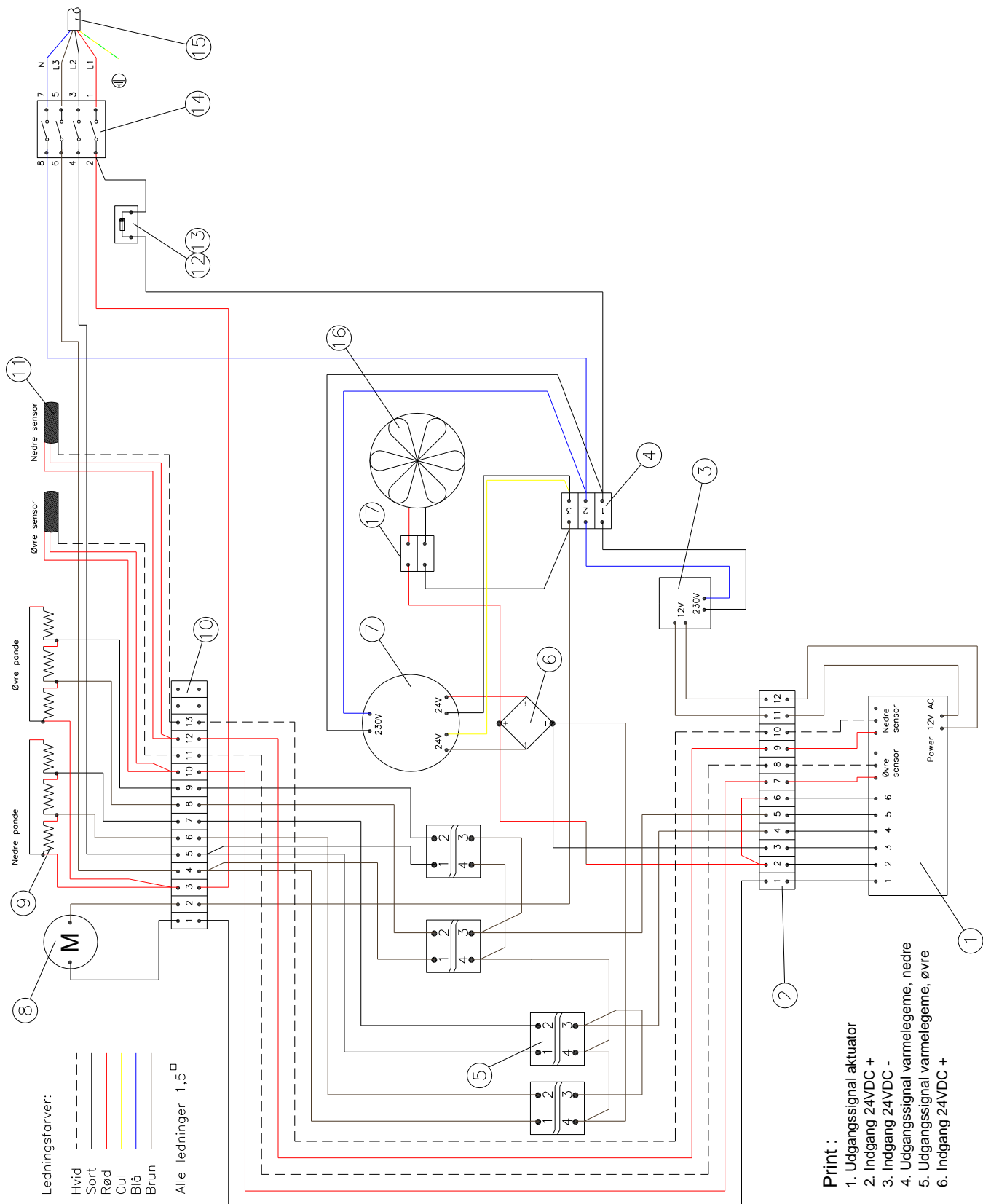

Pos.	Part no.	Pcs.	Description
1	83-10039	1	PCB GL90 serie
2	83-30012	2	Connection block 12-pole
3	83-09056	1	Transformer 230V – 12V 3VA
4	83-07952	1	Connection block 3-pole
5	83-10316	4	Relay SSR 20-265A
6	83-07563	1	Rectifyer
7	84-00294	1	Ringtransformer 230V – 2x24V 80VA
8	83-10022	1	Actuator MLA-2
9	83-09322	6	Heat element 1,85 kW 400V
10	83-30015	1	Connection block 15-pole
11	83-09057	1	Sensor PT100 upper
11a	83-09998	1	Sensor PT100 lower
12	84-00290	1	Fuse holder
13	84-00289	1	Fuse 2A
14	84-00067	1	Switch 4-polet CA25 32A
15	72-03674	1	Connection cable 5 x 2,5 mm ²
16	83-00089	1	Cooling fan 80x80x25 24V
17	83-08156	1	Connection block 2-polet



FKI Fast Food Teknik a/s

Byghøjvej 5, Verninge – DK-5690 Tommerup – Danmark
Tlf. +45 6475 1066 – info@fki.dk – www.fki.dk