

MANUFACTURING
NUMBERS:

9100420
9100424
9100426
9100425
9100428
9100430
9100432
9100433
9100436
9100438
9100439
9100450
9100452
9100456
9100458
9100460
9100462
9100466
9100468
9100480
9100486

roundup

by A.J. Antunes & Co. ®

MIRACLE STEAMER

**Models MS-150/155,
MS-250/255 & MS-355**



P/N 1010699 Rev. N 03/12



MS-255 Shown

Owner's Manual

TABLE OF CONTENTS

Owner information	2	General (MS-150/250 - Mfg. #9100424, 9100432, 433, & 9100439 Only)	10
General	2	Operating Instructions (Except MS-150/250 Mfg. #9100424, 432, 433, & 439).....	11
Warranty Information	2	Operating Instructions (for MS-150/250 Mfg. #9100424, 432, 433, & 439 ONLY).....	11
Service/Technical Assistance	3	Programming	11
Important safety information	3	Hi-Limit Reset Button	13
Specifications	5	Status Indicator LEDs.....	13
Electrical Ratings.....	5	Fault Codes	13
Electrical Cord & Plug Configurations	5	Maintenance	14
Model Designation.....	5	Daily.....	14
Dimensions.....	6	Monthly	14
Installation	7	Technical Theory of Operation	18
Unpacking.....	7	Troubleshooting	19
Model MS-150/155 & MS-355.....	8	Replacement parts	22
Models MS-250/255	9	Wiring diagrams	31
Operation	10	Limited Warranty	Back Cover
General (All Units Except MS-150/250 Mfg. #9100424, 432, 433 & 439)	10		

OWNER INFORMATION

General

The Miracle Steamer produces steam using plain tap water for quick heating and reconstituting of food items. Simple push button action delivers a fully adjustable impulse of steam. Because the amount of steam is consistent, it removes the guesswork and produces a uniform finished product from one operator to the next.

This manual provides the safety, installation and operating procedures for the Miracle Steamer. We recommend that all information contained in this manual be read prior to installing and operating the unit.

Your Miracle Steamer is manufactured from the finest materials available and is assembled to Roundup's strict quality standards. This unit has been tested at the factory to ensure dependable trouble-free operation.

Warranty Information

Please read the full text of the Limited Warranty in this manual.

If the unit arrives damaged, contact the carrier immediately and file a damage claim with them. Save all packing materials when filing a claim. Freight damage claims are the responsibility of the purchaser and **are not** covered under warranty.

The warranty **does not extend to:**

- Damages caused in shipment or damage as result of improper use.
- Installation of electrical service.
- Normal maintenance as outlined in this manual.
- Malfunction resulting from improper maintenance.
- Damage caused by abuse or careless handling.
- Moisture damage to electrical components.
- Damage from tampering with, removal of, or changing any preset control or safety device.

IMPORTANT

A.J. Antunes & Co. reserves the right to change specifications and product design without notice. Such revisions do not entitle the buyer to corresponding changes, improvements, additions or replacements for previously purchased equipment.

IMPORTANT! Keep these instructions for future reference. If the unit changes ownership, be sure this manual accompanies the equipment.

Service/Technical Assistance

If you experience any problems with the installation or operation of your unit, contact your local Roundup Authorized Service Agency. They can be found in the service agency directory packaged with the equipment.

Fill in the information below and have it handy when calling your authorized service agency for assistance. The serial number is on the specification plate located on the rear of the unit.

Purchased From: _____

Date of Purchase: _____

Model No.: _____

Serial No.: _____

Mfg. No.: _____

Refer to the service agency directory and fill in the information below:

Authorized Service Agency

Name: _____

Phone No.: _____

Address: _____

Use only genuine Roundup replacement parts in this unit. Use of replacement parts other than those supplied by the manufacturer will void the warranty. Your Authorized Service Agency has been factory trained and has a complete supply of parts for this unit.

You may also contact the factory at **1-877-392-7854** or **1-630-784-1000** if you have trouble locating your local authorized service agency.

IMPORTANT SAFETY INFORMATION

Throughout this manual, you will find the following safety words and symbols that signify important safety issues with regards to operating or maintaining the Miracle Steamer.

WARNING

GENERAL WARNING. Indicates information important to the proper operation of the equipment. Failure to observe may result in damage to the equipment and/or severe bodily injury or death.

CAUTION

GENERAL CAUTION. Indicates information important to the proper operation of the equipment. Failure to observe may result in damage to the equipment.

WARNING

ELECTRICAL WARNING. Indicates information relating to possible shock hazard. Failure to observe may result in damage to the equipment and/or severe bodily injury or death.

WARNING

HOT SURFACE WARNING. Indicates information important to the handling of equipment and parts. Failure to observe caution could result in personal injury.

IMPORTANT SAFETY INFORMATION (continued)

In addition to the warnings and cautions in this manual, use the following guidelines for safe operation of the unit.

- Read all instructions before using equipment.
- For your safety, the equipment is furnished with a properly grounded cord connector. Do not attempt to defeat the grounded connector.
- Install or locate the equipment only for its intended use as described in this manual. Do not use corrosive chemicals in this equipment.
- Do not operate this equipment if it has a damaged cord or plug, if it is not working properly, or if it has been damaged or dropped.
- This equipment should be serviced by qualified personnel only. Contact the nearest Roundup authorized service facility for adjustment or repair.
- Do not block or cover any openings on the unit.
- Do not immerse cord or plug in water.
- Keep cord away from heated surfaces.
- Do not allow cord to hang over edge of table or counter.

The following warnings and cautions appear throughout this manual and should be carefully observed.

- Turn the unit off, disconnect the power source and allow unit to cool down before performing any service or maintenance on the unit.
- The equipment should be grounded according to local electrical codes to prevent the possibility of electrical shock. It requires a grounded receptacle with separate electrical lines, protected by fuses or circuit breaker of the proper rating.
- All electrical connections must be in accordance with local electrical codes and any other applicable codes.
- **WARNING ELECTRICAL SHOCK HAZARD. FAILURE TO FOLLOW THESE INSTRUCTIONS COULD RESULT IN SERIOUS INJURY OR DEATH.**
 - Electrical ground is required on this appliance.
 - Do not modify the power supply cord plug. If it does not fit the outlet, have a proper outlet installed by a qualified electrician.
 - Do not use an extension cord with this appliance.

- Check with a qualified electrician if you are in doubt as to whether the appliance is properly grounded.
- This equipment is to be installed to comply with the basic plumbing code of the Building Officials and Code Administrators, Inc. (BOCA) and the Food Service Sanitation Manual of the Food and Drug Administration (FDA).
- If the supply cord is damaged, it must be replaced by the manufacturer or its service agent, or a similarly qualified person.
- Do not clean this appliance with a water jet.
- Do not use a sanitizing solution or abrasive materials. The use of these may cause damage to the stainless steel finish.
- To ensure proper steaming characteristics, some calcium/mineral deposits must be present on the generator surface. If, during cleaning, the surface does become free of calcium/mineral deposits, one approved method is to add plain tap water to the surface and allow it to boil off. This will ensure proper steaming characteristics by creating a thin layer of deposits on the surface.
- Chlorides or phosphates in cleansing agents (such as bleach, sanitizers, degreasers or detergents) could cause permanent damage to stainless steel equipment. The damage is usually in the form of discoloration, dulling of metal surface finish, pits, voids, holes or cracks. This damage is permanent and not covered by warranty.
- The following tips are recommended for maintenance of your stainless steel equipment,
 - Always use a soft, damp cloth for cleaning, rinse with clear water and wipe dry. When required, always rub in direction of metal polish lines.
 - Routine cleaning should be done daily using soap, ammonia detergent and water.
 - Stains and spots should be sponged using a vinegar solution as required.
 - Finger marks and smears should be rubbed off using soap and water.
 - Hard water spots should be sponged using a vinegar solution.

SPECIFICATIONS

Electrical Ratings

Model	Mfg. Number	Voltage	Watts	Amps	Hertz
MS-150CV	9100420	208	3300	15.9	50/60
MS-150CV	9100424	208	3300	15.9	50/60
MS-150CV	9100426	230	3300	14.4	50/60
MS-150CF	9100425	120	1800	15.0	50/60
MS-150HC	9100428	230	3300	14.4	50/60
MS-250CV	9100430	208	3300	15.9	50/60
MS-250CV	9100432	208	3300	15.9	50/60
MS-250CV	9100433	230	3300	14.4	50/60
MS-250CV	9100436	230	3300	14.4	50/60
MS-250HC	9100438	230	3300	14.4	50/60
MS-250CF	9100439	120	1800	15.0	50/60
MS-155CV	9100450	208	3300	15.9	50/60
MS-155CF	9100452	120	1800	15.0	50/60
MS-155CV	9100456	230	3300	14.4	50/60
MS-155HC	9100458	230	3300	14.4	50/60
MS-255CV	9100460	208	3300	15.9	50/60
MS-255CF	9100462	120	1800	15.0	50/60
MS-255CV	9100466	230	3300	14.4	50/60
MS-255HC	9100468	230	3300	14.4	50/60
MS-355CV	9100480	208	3300	15.9	50/60
MS-355CV	9100486	230	3300	14.4	50/60

⚠ CAUTION ⚠

All electrical connections must be in accordance with local electrical codes and any other applicable codes.

⚠ CAUTION ⚠

Be sure to follow all safeguards and precautions in the Important Safety Instructions section of this manual.

Electrical Cord & Plug Configurations

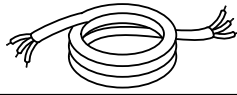
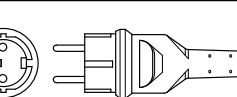
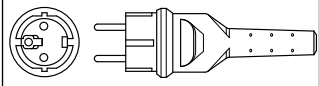
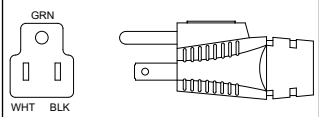
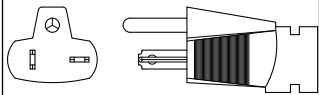
Letter Code*	Description	Configuration
C	Commercial Cord	
H	Harmonized Cord	
(H)C**	CEE 7/7, 16 Amp., 250 VAC (Assembly Only).	
(C)F***	5-15P, 15 Amp., 120 VAC., Non – Locking (Assembly Only).	
(C)V***	6-20P, 20 Amp., 250 VAC., Non – Locking (Assembly Only).	

* Used in Model Designation

** Indicates that the plug comes with a Harmonized Cord

*** Indicates that the plug comes with a Commercial Cord

Model Designation

MS-150XX

TYPE OF POWER CORD

H = HARMONIZED
C = COMMERCIAL

TYPE OF PLUG

C = CEE 7/7 Schuko
F = NEMA 5-15P
V = NEMA 6-20P

50 = Timer/Spatula Model
55 = Timer/Drawer Model

1 = Self-Contained Water Tank
2 = Direct Water Hook-Up
3 = Front Water Drawer

SPECIFICATIONS (continued)

Dimensions

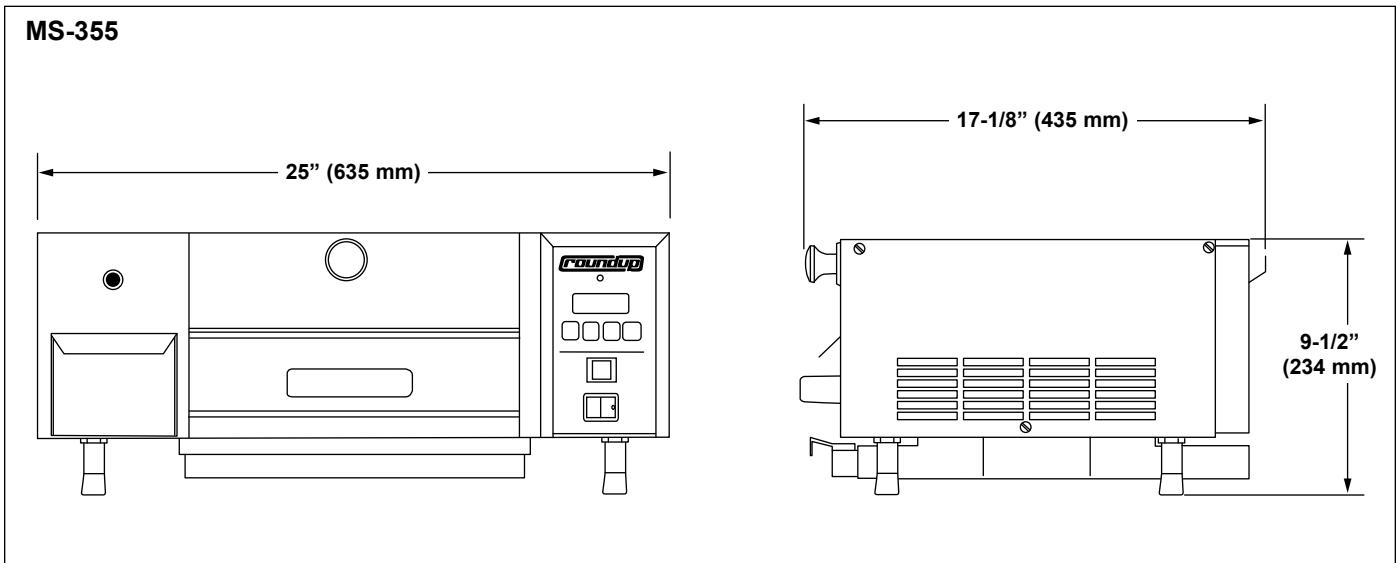
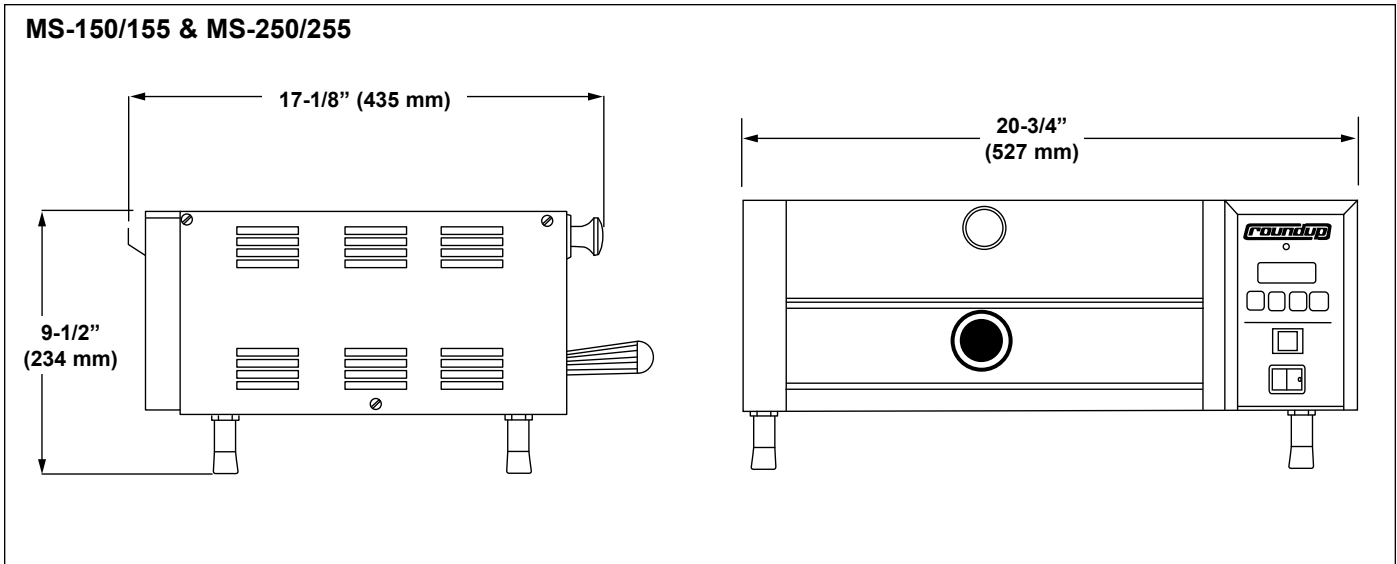

INSTALLATION

Unpacking

1. Remove the unit and all packing materials from the shipping carton.
2. The unit should come with the items listed below:
 - Owner's Manual
 - Authorized Service Agency Directory
 - Inlet Hose Assembly (MS-250/255 only)
 - Spatula Assembly (MS-150/250 only)
 - Drawer Assembly (MS-155/255/355 only)

NOTE: If any parts are missing or damaged, contact Antunes Technical Service IMMEDIATELY at 1-877-392-7854 or 1-630-784-1000.

3. Remove all packing materials and protective coverings from the unit.
4. Remove and wash all removable parts in soap and water. Rinse with clean hot water and allow to air dry.
5. Wipe all surfaces of the unit with a hot, damp cloth.

NOTE: Do not use a dripping wet cloth. Wring out before use.

6. **MS-150/250 Models:** Assemble the Guard and Mounting Bolt to the Spatula as shown in Figure 1.
7. Install the Wire Trivet into side slots on Spatula.
8. Re-install all removed parts.

Equipment Setup

GENERAL

When placing the unit into service, pay attention to the following guidelines:

- Make sure power to the unit is off and the unit is at room temperature.
- Do not block or cover any openings on the unit.
- Do not immerse cord or plug in water.
- Keep cord away from heated surfaces.
- Do not allow cord to hang over edge of table or counter.

ELECTRICAL

1. Place the unit on a sturdy, level table or other work surface.

2. Ensure that the line voltage corresponds to the stated voltage on the units specification label and power cord warning tag. **If you are unsure of your Line Voltage, contact your electrician.**
3. Connect the unit to the power supply.

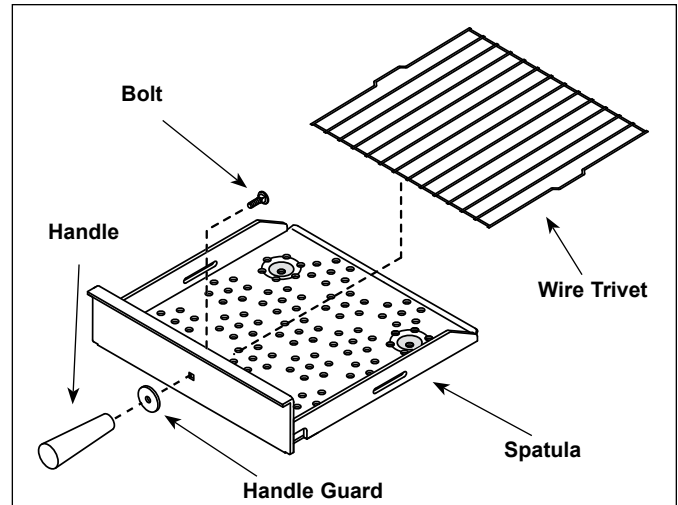







Figure 1. Assembling Handle—MS-150/250 Only

 WARNING THIS APPLIANCE MUST BE EARTHED (GROUNDED)	 WARNING THIS APPLIANCE MUST BE EARTHED (GROUNDED)
120 VAC ONLY	THIS UNIT IS DESIGNED TO OPERATE ON 120 VOLTS ONLY. APPLICATION WITH ANY OTHER VOLTAGE SUPPLY COMPLETELY VOIDS ALL WARRANTY . PLEASE CHECK YOUR LINE VOLTAGE BEFORE INSERTING THIS PLUG INTO THE RECEPTACLE.

 WARNING THIS APPLIANCE MUST BE EARTHED (GROUNDED)	 WARNING THIS APPLIANCE MUST BE EARTHED (GROUNDED)
208 VAC ONLY	THIS UNIT IS DESIGNED TO OPERATE ON 208 VOLTS ONLY. APPLICATION WITH ANY OTHER VOLTAGE SUPPLY COMPLETELY VOIDS ALL WARRANTY . PLEASE CHECK YOUR LINE VOLTAGE BEFORE INSERTING THIS PLUG INTO THE RECEPTACLE.

 WARNING THIS APPLIANCE MUST BE EARTHED (GROUNDED)	 WARNING THIS APPLIANCE MUST BE EARTHED (GROUNDED)
220-240 VAC ONLY	THIS UNIT IS DESIGNED TO OPERATE ON 220-240 VOLTS ONLY. APPLICATION WITH ANY OTHER VOLTAGE SUPPLY COMPLETELY VOIDS ALL WARRANTY . PLEASE CHECK YOUR LINE VOLTAGE BEFORE INSERTING THIS PLUG INTO THE RECEPTACLE.

INSTALLATION (continued)

⚠ CAUTION ⚠

Be sure to follow all safeguards and precautions in the Important Safety Instructions section of this manual.

⚠ CAUTION ⚠

All electrical connections must be in accordance with local electrical codes and any other applicable codes.

PLUMBING

NOTE: Miracle Steamer models are designed to use cold tap water. Distilled water may be used to reduce calcium/mineral deposit build-up and reduce maintenance costs.

⚠ CAUTION ⚠

This equipment is to be installed to comply with the basic plumbing code of the Building Officials and Code Administrators, Inc. (BOCA) and the Food Service Sanitation Manual of the Food and Drug Administration (FDA).

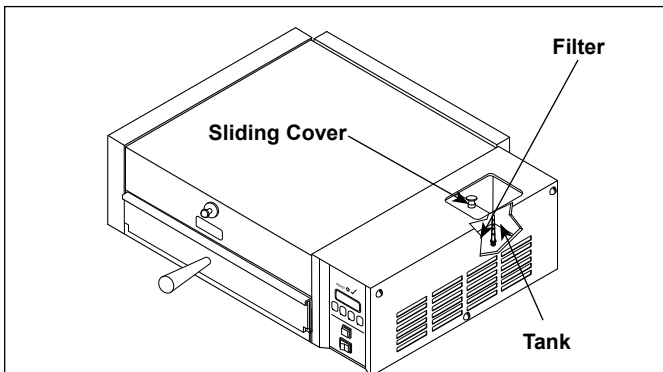

Figure 2. Filling Water Tank–MS-150/155

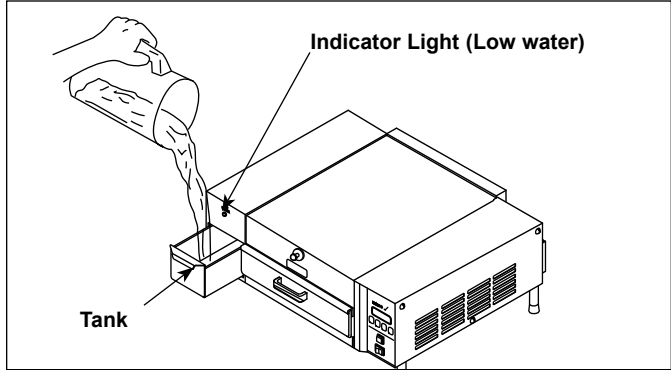

Figure 3. Filling Water Tank–MS-355

Model MS-150/155 & MS-355

The MS-150/155 & MS-355 models have a self-contained water tank. To fill the self-contained water tank:

1. **MS-150/155:** Open the sliding tank cover on top of the unit (Figure 2).

NOTE: Make sure filter inside tank is installed properly.

2. Pour in **cold tap water**. The tank will hold approximately 3 quarts (2.81 liters).
3. Close the sliding tank drawer.

⚠ CAUTION ⚠

Do NOT overfill the unit water tank. Fill the tank to 90% full ONLY.

INSTALLATION (continued)

Models MS-250/255

⚠ CAUTION ⚠

Water pressure must not exceed 30 psi (2.1 kg/cm² or 207 kPa). Higher water pressures may cause poor performance or flooding. To reduce water pressure, install a water pressure regulator, and set water pressure to 20-25 psi (1.4 - 1.7 kg/cm² or 138 - 172 kPa).

These models require a direct cold water hookup. A Water Inlet Hose and Strainer Assembly (Figure 4) is supplied.

NOTE: Incoming water is controlled by a normally closed (NC) solenoid valve located inside the Steamer's electrical housing.

1. Turn off the water valve (not supplied) that supplies water to the unit (Figure 4).
2. Connect the 1/4" (6.5 mm) I.D. Flexible Tubing to the outlet side of the Water Pressure Regulator and secure using the worm clamp as shown in Figure 4.

NOTE: A Water Pressure Regulator must first be installed as shown in Figure 4. Failure to do so will result in poor steaming and possible flooding. For a single steamer, use Water Pressure Regulator P/N 7000314. For two adjacent steamers, use Water Pressure Regulator P/N 7000235.

3. Turn the water valve on.
4. Over a bucket, press and hold the white plastic tip on the Quick Disconnect Insert (Figure 4) until good, steady water flow is noted (this will purge all air out of the line). Release and note the pressure on the Water Pressure Regulator gauge. It should read 20-25 PSI. If it reads more or less, adjust the pressure by pulling the black knob upwards and turning it clockwise to increase or counter-clockwise to decrease the water pressure. Push the knob down to lock it in place.

NOTE: When adjusting the knob, you must relieve the existing pressure by pressing the white plastic tip on the Quick Disconnect Insert for 3 seconds. This allows the newly set pressure to register on the gauge. Repeat this until the gauge reads 20-25 PSI.

5. Push the Quick Disconnect Insert into the fitting at the rear of the unit until a "click" is heard (Figure 4).

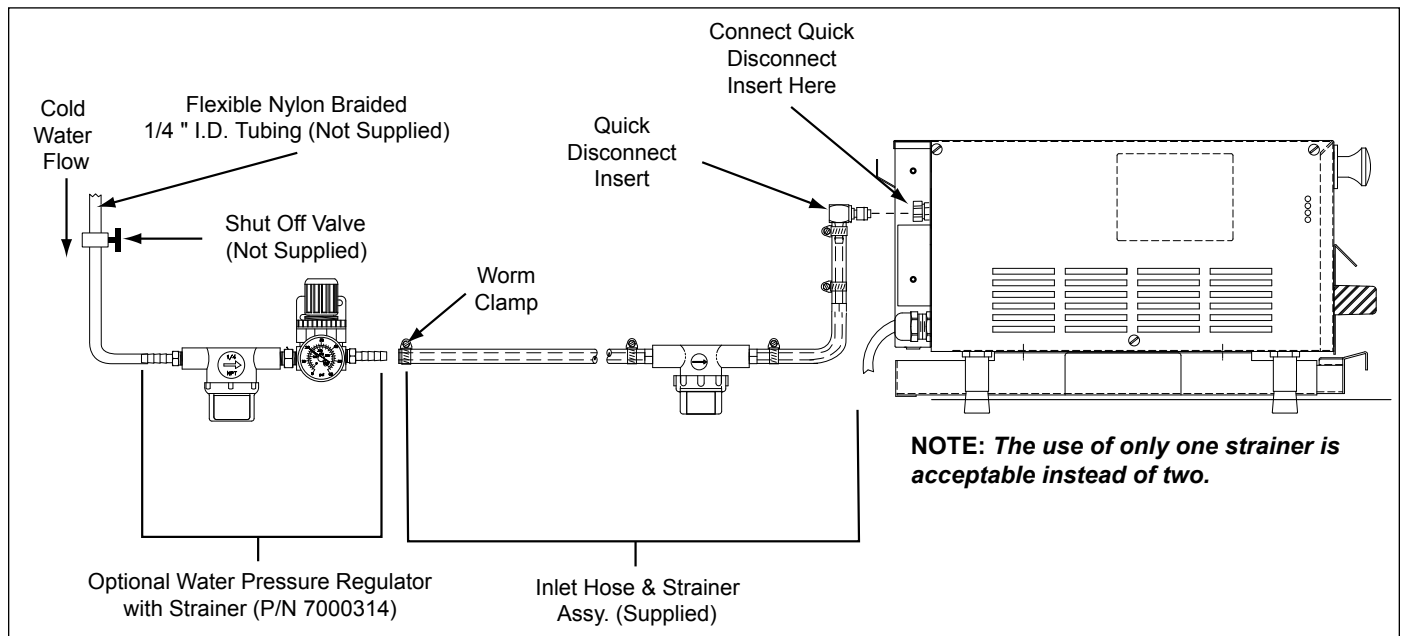

Figure 4. Connecting Water Supply to MS-250/255

OPERATION

General (All Units Except MS-150/250 - Mfg. #9100424, 432, 433 & 439)

When the Operate button (Figure 5a) is pressed, power is supplied to the water pump (MS-150/155/355) or the solenoid valve (MS-250/255). The pump/solenoid operates and water sprays onto the heated Steam Generator. The water flashes immediately into live steam and shoots down onto the product.

One of two operational modes can be used: **Single Shot** or **Timed Cycle**

SINGLE SHOT

The Operate button is pressed to initiate a single steam shot. The control board applies power to the water pump/solenoid and a “shot” of steam occurs.

TIMED CYCLE

The control is used to set the desired cook time (up to 99 minutes, 59 seconds). When the Start/Stop button is pressed, the Control Board applies power to the water pump/solenoid at regular intervals for the duration of the displayed cycle time. The display counts down to zero and, when the cycle is complete, sounds an audible signal, and then reverts back to the original programmed cycle time. The unit is ready for the next cycle when the green ready light is on.

General (MS-150/250 - Mfg. #9100424, 9100432, 433, & 9100439 Only)

When the Single Shot button (Figure 5b) is pressed, power is supplied to the Solenoid/Water Pump. The solenoid/ water pump operates and water sprays onto the heated Steam Generator. The water flashes immediately into live steam and shoots down onto the product.

One of two operational modes can be used: **Single Shot** or **Timed Cycle**

SINGLE SHOT

The Single Shot button is pressed to initiate a single steam shot. The Control Board applies power to the Solenoid/Water pump and a “shot” of steam occurs.

TIMED CYCLE

The control is used to set the desired cook time (up to 99 minutes, 59 seconds). When the Operate button is pressed, the Control Board applies power to the solenoid at regular intervals for the duration of the displayed cycle time. The display counts down to zero and, when the cycle is complete, sounds an audible signal, and then reverts back to the original programmed cycle time. The unit is ready for the next cycle when the green ready light is on.

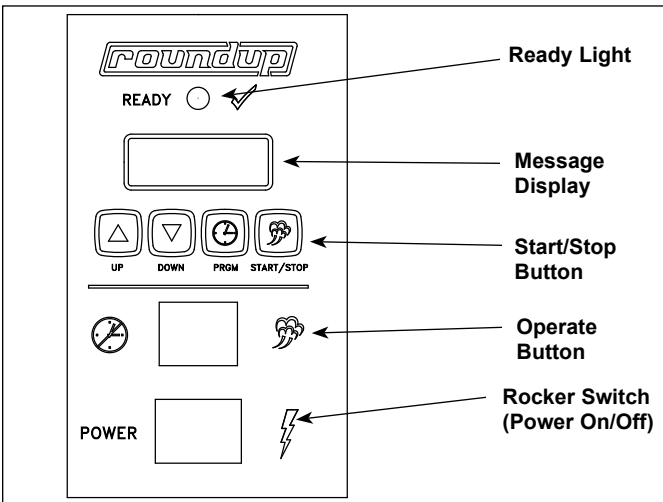

Figure 5a. Operating Controls (all units EXCEPT MS-150/250 Mfg. #9100424, 9100432, 9100433, & 9100439)

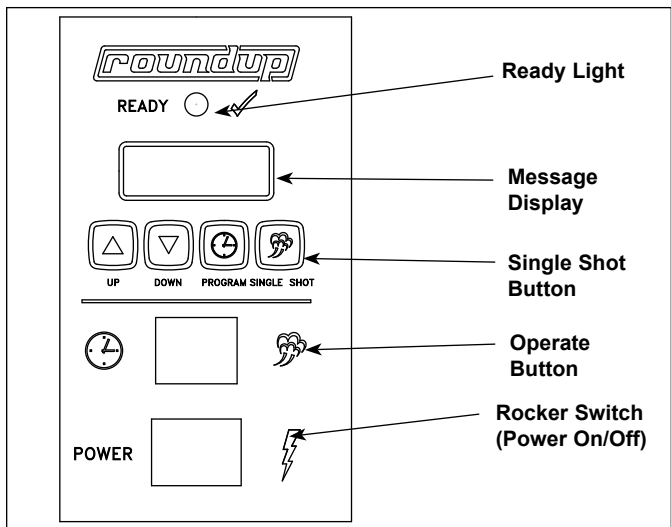

Figure 5b. Operating Controls (MS-150/250 Mfg. #9100424, 9100432, 9100433, & 9100439 ONLY)

OPERATION (continued)

IMPORTANT: 208V and 220/240V Miracle Steamers are factory programmed for the following recommended settings:

- **Total Cycle Time (CYC)** = 15 min., 00 secs.
(Range: 3 seconds to 99 minutes 59 seconds)
- **Shot Interval Time (SHO)** = 00 min., 20 secs.
(Range: 3 seconds to 5 minutes 59 seconds)
- **Steam Shot Time (H₂O)** =
MS-150/155/355 - (1_00)
MS-250/255 - (0_70)
(Range: 0_10 second to 2_50)

This converts approximately 3/4 oz. (25 milliliters) of water to steam every 20 seconds for a 15 minute cooking cycle. To change any of these settings see **PROGRAMMING** on this page.

IMPORTANT: 120V Miracle Steamer is factory programmed for the following recommended settings:

- **Total Cycle Time (CYC)** = 2 min., 00 secs.
(Range: 3 seconds to 99 minutes 59 seconds)
- **Shot Interval Time (SHO)** = 00 min., 20 secs.
(Range: 3 seconds to 5 minutes 59 seconds)
- **Steam Shot Time (H₂O)** =
MS-250/255 - (0_40)
MS-150/155/355 - (0_80)
(Range: 0_10 seconds to 2_50)

Operating Instructions (Except MS-150/250 Mfg. #9100424, 432, 433, & 439)

1. Turn the Rocker Switch (power On/Off) to ON (Figure 5a).
2. Allow the unit to preheat for approximately 20-30 minutes.

NOTE: Do not push any of the buttons during warm-up time. The flashing green ready light indicates that the unit is NOT up to temperature. The flashing green ready light will become STEADY when the unit is up to temperature.

3. Pull out the Spatula or Drawer Assembly and place the product to be steamed onto the Spatula.
4. Push the Spatula or Drawer Assembly fully into the steamer.
5. **Single Shot:** Press and release the Operate button, wait 20 seconds for the steam to penetrate the product.

Timed Cycle: Press the Start/Stop button to begin the steaming cycle. The display will count down to zero and an audio signal will sound at the end of the steaming cycle.

⚠WARNING⚠

To avoid injury, be careful when pulling Spatula or Drawer out from unit. Be sure to allow steam to escape before putting hands or face over the steamer.

6. Remove steamed product.

Operating Instructions (for MS-150/250 - Mfg. #9100424, 432, 433, & 439 ONLY)

1. Turn the unit on (Figure 5b).
2. Allow the unit to preheat for approximately 20-30 minutes.

NOTE: Do not push any buttons during warm-up time. The flashing green ready light indicates that the unit is NOT up to temperature. The flashing green ready light will become STEADY when the unit is up to temperature.

3. Pull out the spatula and place the product to be steamed onto the spatula.
4. Push the spatula fully into the steamer.
5. **Single Shot:** Press and release the Single Shot button, wait 20 seconds for the steam to penetrate the product.

Timed Cycle: Press the Operate button to begin the steaming cycle. The display will count down to zero and an audio signal will sound at the end of the steaming cycle.

⚠WARNING⚠

To avoid injury, be careful when pulling spatula or Drawer out from unit. Be sure to allow steam to escape before putting hands or face over the steamer.

6. Remove steamed product.

Programming

CYC (Total Cycle Time) refers to the total programmed steam time set for the product.

SHO (Shot Interval Time) is the time set between shots of steam during a complete cycle.











H₂O setting (Steam Shot Time) is used to adjust the water volume consumed during each water pump or solenoid valve activation.

OPERATION (continued)

The amount of steam produced by your Miracle Steamer depends on the amount of water sprayed onto the steam generator.



Flooding of the generator may occur if the H2O setting is set too high. To prevent flooding, the Shot Interval Time (SHO) can be increased to allow more time for generator heat recovery. Adjustments should be made to both values to determine the optimum settings for your cooking needs.

To program the control, refer to Figure 6 and follow the procedure below:

1. Turn the unit on. The unit displays the factory programmed Total Cycle Time in minutes and seconds (Item A, Figure 6).
2. Press and release  change the control from OPERATION to PROGRAM mode.
3. To change the Total Cycle Time in minutes, press  or  to change the time (Item B, Figure 6).
4. Press and release  again, and press  or  to change the Total Cycle Time in seconds (Item C, Figure 6).
5. To change the SHO factory settings, make sure the control is in PROGRAM mode, then press and hold both  and  simultaneously for 1-2 seconds and then release. SHO will be displayed (Item D, Figure 6).
6. Press and release  and then press  or  to change the SHO in seconds (Item E, Figure 6).

7. Press and release  again and press  or  to change the SHO in minutes (Item F, Figure 6).

NOTE: 00 minutes is recommended.

8. Press and release the Program button again and H₂O will be displayed (Item G, Figure 6).
9. To change the H₂O (Steam Shot time), press and release the Program button again to display the setting (Item H, Figure 6). Use  or  to increase or decrease the time.

NOTE: Recommended settings are:

MS-150/155/355 (0_80) 120 Volt units only

MS-250/255 (0_40) 120 Volt units only

MS-150/155/355 (1_00) 208-240 Volt units only

MS-250/255 (0_70) 208-240 Volt units only

10. Press either the Start/Stop, Single Shot, or Operate buttons to store the changes, exit the PROGRAM Mode and initiate the cooking cycle.

NOTE: The Start/Stop, Single Shot, or Operate buttons may be pressed at any time during programming to store the changes and exit the PROGRAM Mode.

NOTE: If a change is not made within 5 seconds at any time during the programming process, all changes made up to that point are stored in memory and the control reverts to the OPERATION Mode.

NOTE: 20 seconds is recommended.

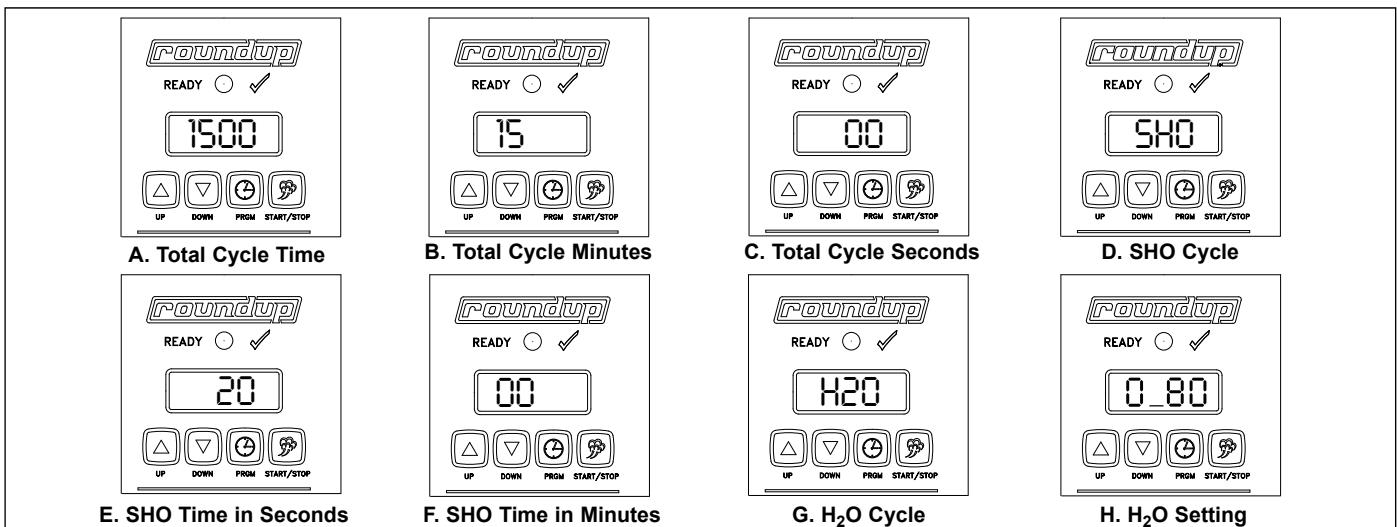

Figure 6. Control Programming Sequence

OPERATION (continued)

Hi-Limit Reset Button

A hi-limit thermostat turns off electrical power to the steam generator if it overheats. To reset this thermostat, allow approximately 45 minutes for the unit to cool down, remove the black cap, and then press the black reset button located on the rear of the unit (Figure 7). If the unit requires continuous resetting, contact your Roundup authorized service agency.

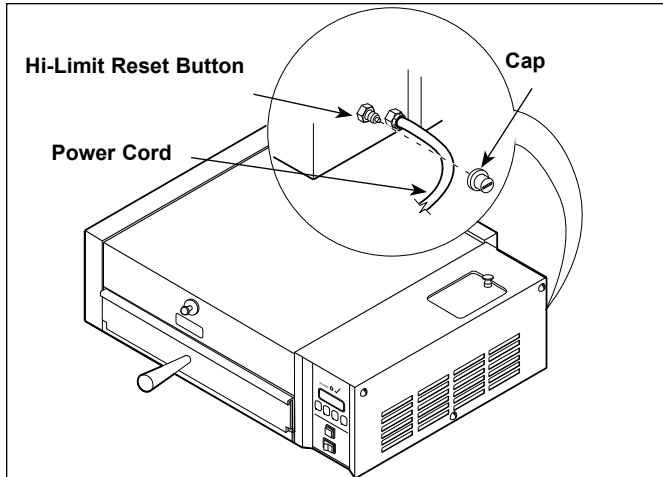

Figure 7. Hi-Limit Reset Button (MS-150 shown)

Status Indicator LEDs

The Miracle Steamer's Control Board has 4 Status Indicator LEDs described below:

Green (Program): When lit, indicates the unit is in Program mode.

Yellow (Audio): When lit, indicates 10-15 VDC is being supplied to the audio signal. The audio signal sounds and the LED lights for approximately 3 seconds.

Red (Heat): When lit, indicates the Control Board is calling for heat by supplying 10-15 VDC to the Solid State Relay. When off, indicates that the unit is satisfied.

Green (H2O): When lit, indicates that 24 VAC is being supplied to operate the solenoid valve (MS-250/255) or water pump (MS-150/155/355). **This LED is only lit for approximately 1 second.**

Fault Codes

When the programming parameters for Minutes/Seconds/SHO/H2O have been inadvertently changed below or above their limits, the unit displays the "ERR" fault code. If this code appears, clear these settings using the procedure below:

1. Turn the unit off.
2. Press and hold the Program and Start/Stop buttons simultaneously (for all units except MS-150/250 with Mfg. number 9100424, 432, 433 & 439) or Up and Down Arrow buttons for MS-150/250 with Mfg. number 9100424, 432, 433, & 439 only).
3. Turn the unit on while holding the appropriate buttons. Release the buttons when the unit stops beeping.
4. The display will now register the cycle time.

NOTE: Repeat these steps if the unit still displays the ERR fault code.

NOTE: It is recommended that the SHO and H2O settings be adjusted to the recommended settings shown in the Programming section of this manual.

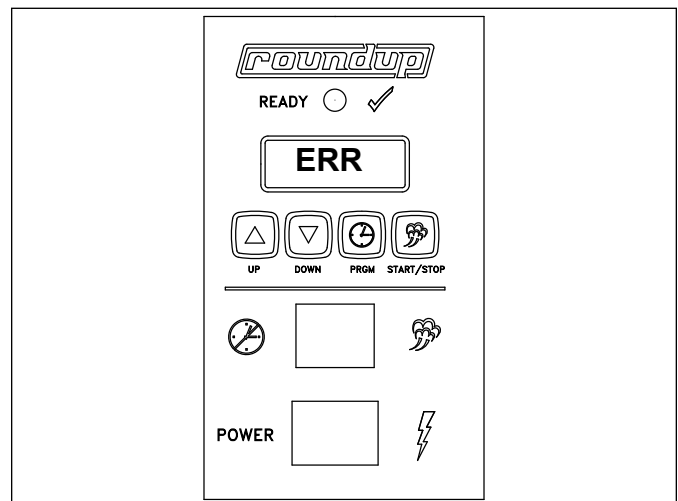

The "ERR" Fault Code

MAINTENANCE

⚠ WARNING ⚠

Turn the unit off, disconnect the power source and allow the unit to cool down before performing any service or maintenance on the unit.

⚠ CAUTION ⚠

Chlorides or phosphates in cleansing agents (such as bleach, sanitizers, degreasers or detergents) could cause permanent damage to stainless steel equipment. The damage is usually in the form of discoloration, dulling of metal surface finish, pits, voids, holes or cracks. This damage is permanent and not covered by warranty. The following tips are recommended for maintenance of your stainless steel equipment:

- Always use a soft, damp cloth for cleaning, rinse with clear water and wipe dry. When required, always rub in direction of metal polish lines.
- Routine cleaning should be done daily using soap, ammonia detergent and water.
- Stains and spots should be sponged using a vinegar solution.
- Finger marks and smears should be rubbed off using soap and water.
- Hard water spots should be sponged using a vinegar solution.

NOTE: Frequency of cleaning is determined by water conditions, usage and water filtration systems.

⚠ CAUTION ⚠

Do not use a sanitizing solution or abrasive materials. The use of these may cause damage to the stainless steel finish.

⚠ CAUTION ⚠

If a chemical cleaner is used, be sure it is safe to use on cast aluminum. Observe all precautions and warnings on product label.

⚠ CAUTION ⚠

Unplug power cord before moving and servicing this appliance.

Daily

1. Turn the unit OFF. Unplug the power cord and allow the unit to cool down before proceeding.
2. Check the Water Pressure Regulator gauge (MS-250/250 only) and verify that it reads 20 - 25 PSI (1.4 - 1.7 kg/cm² or 138-172 kPa). If not, adjust the water pressure as described in the Installation section of this manual. Check the rear water Quick Disconnect Fitting and Hose Clamp for leakage. Tighten clamps or replace parts if needed.
3. Remove the Spatula (MS-150/250 only), Drawer (MS-155/255/355 only), Liner, Drip Pan, Top Cover, and Steam Vent (Figure 8).
4. Wash items in hot, soapy water and then rinse and **WIPE DRY**.
5. Wipe down the food compartment and the entire exterior of the unit (Figure 8) with a clean, hot, damp cloth (not dripping wet) and wipe dry.
6. Reinstall the Steam Vent first, followed by the remaining items.

NOTE: Install steam vent before installing liner and drawer/spatula.

NOTE: Failure to properly clean and dry the above mentioned items prior to reassembly may result in the accumulation of water/moisture overnight. This may lead to permanent damage of the equipment's finish and its accessories. This damage is not covered by warranty.

Monthly

The Miracle Steamer utilizes an open steam generator. Water sprayed onto the generator surface flashes into steam immediately, but the minerals in the water do not steam, they stay on the generator surface. **A small amount of calcium/mineral deposits are needed for proper operation**, but a build-up of excessive calcium/mineral deposits causes poor steaming efficiency, excessive moisture (wet steam) and will eventually severely retard the steaming action completely.

MAINTENANCE (continued)

CLEANING STEAM GENERATOR

1. Turn the unit off and unplug the power cord. Allow the unit to cool down before proceeding.
2. Perform the Daily cleaning, but **DO NOT** reassemble the unit
3. Remove the wing nut, Generator Cover, and Diffuser (Figure 8). Wash these items in hot, soapy water, rinse and **WIPE DRY**.
4. With the unit cool, use a wire brush and/or scraper to loosen and remove the excessive calcium/mineral deposits from the generator surface (Figure 8). Next, take a wire brush and clean out any build up that has accumulated in the 28 steam ports (26 vertical and 2 horizontal) of the generator (Figure 8). Remove the loose build up, wipe the generator with a clean, damp cloth, and reassemble the unit.

NOTE: If deposits are still excessive and/or difficult to remove, refer to Steps 5 and 10.

5. Pour delimer solution (not supplied) onto the generator surface. Follow the delimer manufacturer's instructions for proper mixture and use.

⚠ CAUTION ⚠

If a chemical cleaner/delimer is used, be sure it is safe to use on cast aluminum. Observe all precautions and warnings on the product label.

6. Using a sponge or a dry towel, remove the delimer solution from the generator surface, then rinse with clean water.

NOTE: To ensure proper steaming characteristics, some calcium/mineral deposits must be present on the generator surface. If, during cleaning, the surface does become free of calcium/mineral deposits, add plain tap water to the surface and allow it to boil off. If necessary, repeat this process to formulate a thin coating of calcium/mineral deposits.

NOTE: In soft water areas, it may be necessary to add a small amount of lime to the generator to "season" it. This will ensure proper steaming characteristics by producing a thin coating of calcium/mineral deposits on the generator surface.

Seasoning mixture consists of 3/4 ounces (25ml/25cc) baking soda, 3/4 ounces (25ml/25cc) lime mixed with 1 quart (950ml/950cc) of water. Stir mixture and pour 1/4" deep onto the hot generator surface. After mixture is converted to steam, the remaining loose power can be removed.

7. Plug the power cord into the appropriate outlet.
8. Turn the unit ON. Allow the unit to warm up for approximately 30 minutes.
9. Push and release the Operate button or the Single Shot button several times to operate the steamer. **This purges any remaining delimer residue from the generator surface.**
10. Turn the unit off, reinstall all parts and accessories, and return the unit to service.

MAINTENANCE (continued)

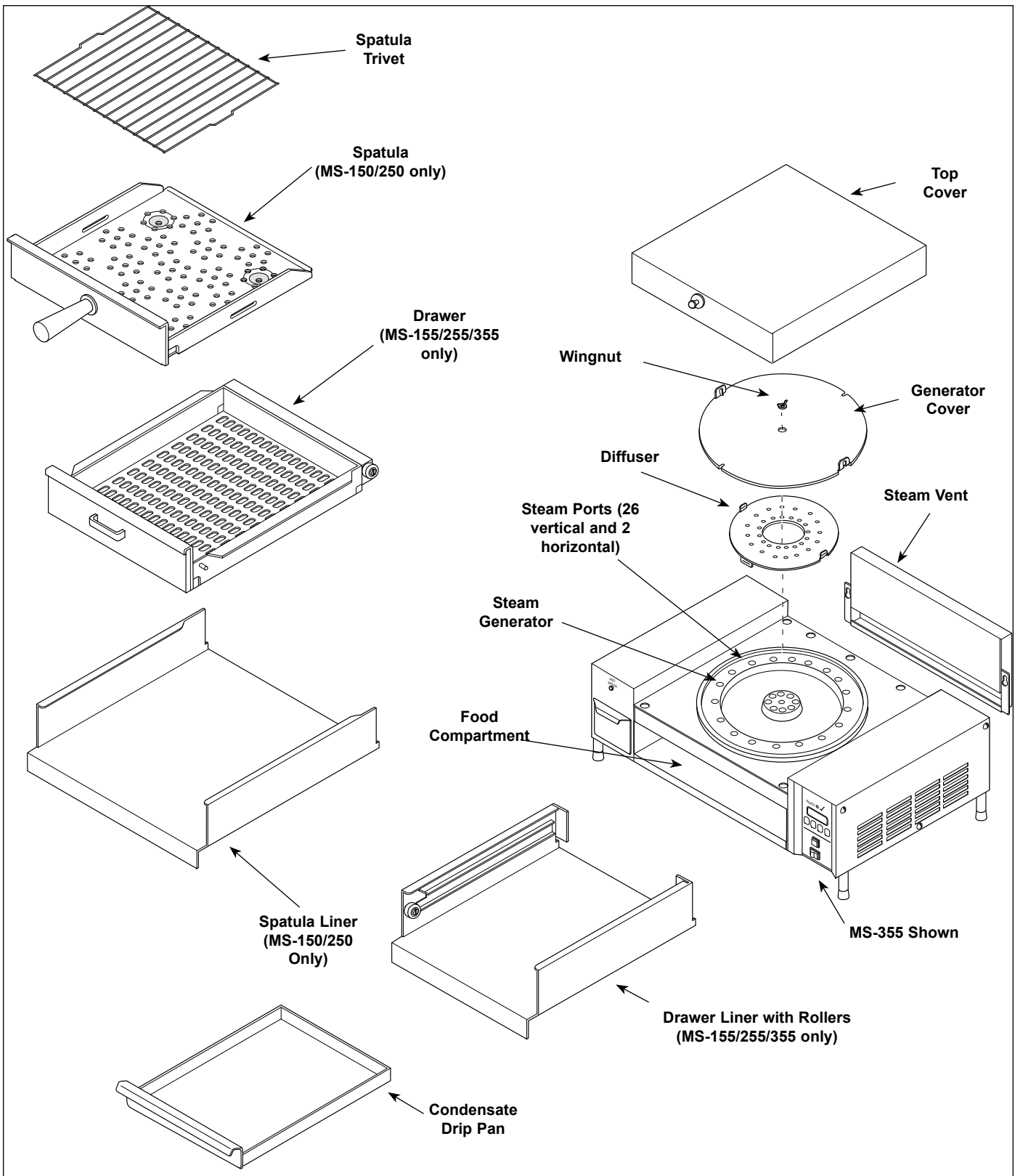

Figure 8. Miracle Steamer Components

MAINTENANCE (continued)

WATER TANK FILTER—MODELS MS-150/155 ONLY

The Water Tank Filter is used to prevent solids or food products from entering and damaging the water pump. The unit uses a water filter (Figure 9). Inspect and clean this filter monthly or more regularly using the following procedure:

NOTE: The water level should be very low or near empty.

1. Turn the unit OFF. Unplug the power cord and allow the unit to cool down before proceeding.
2. Open the Slide Door (Figure 9).
3. Remove the filter, located inside the tank, by pulling it upwards and out of the bottom hole.
4. Clean the Filter by running it under tap water. Replace the Filter if the screen is torn or damaged.

5. Reinstall the filter stem into the bottom hole of the tank (Figure 9).
6. Fill the Water Tank and test the unit.

NOTE: The MS-355 does not use a water filter.

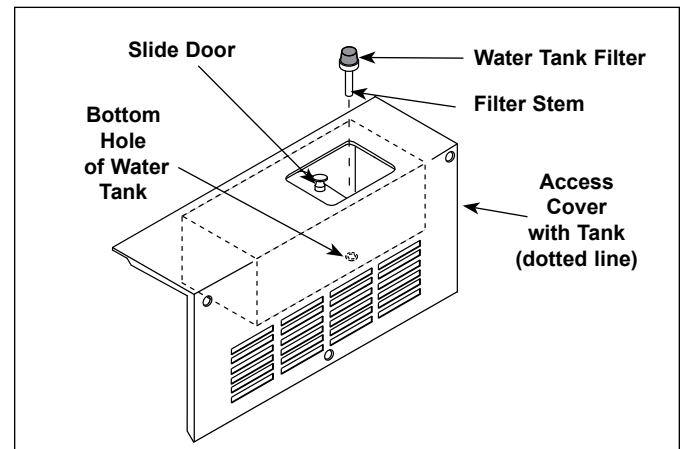

Figure 9. Water Tank Filter—MS-150/155 Only

CHECKING AND CLEANING THE WATER STRAINER (MONTHLY MS-250/255 ONLY)

The Water Strainer protects your equipment from any foreign debris in the water line that could get into the food, damage the unit's solenoid (causing the unit to leak or flood) and protect from interference with the equipment's proper and consistent operation

To ensure proper and consistent steaming results, visually check the water pressure regulator gauge and strainer cup regularly. If the pressure on the gauge has dropped, visually check the clear, plastic strainer "cup" and clean out the accumulated debris as follows.

1. Shut off the water supply valve to the unit, unscrew the clear, plastic strainer "cup" and carefully remove the mesh strainer screen.

2. At the sink, gently flush all of the accumulated debris from the strainer cup and mesh strainer. Be especially careful not to damage the mesh strainer screen.
3. Carefully place the mesh strainer screen into its seat at the bottom of the clear, plastic cup and confirm that the orange O-ring is properly seated in its place before screwing the strainer cup and top back together.
4. Purge the air out of the strainer and tubing by disconnecting the male quick disconnect insert from the equipment and, over a bucket, push the "white" plastic tip in until there is good water flow.
5. Replace damaged or worn parts as needed.
6. Verify that the Water Pressure Regulator is set to 20-25 PSI (1.4-1.7 kg/cm² or 138-172 kPa).

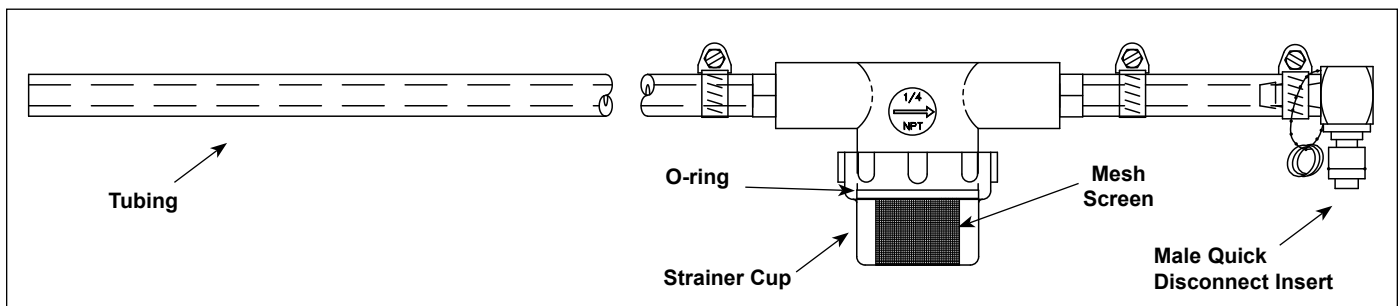

Figure 10. Inlet Hose Assembly

MAINTENANCE (continued)

Technical Theory of Operation

When the Rocker Switch (power On/Off) is ON, line voltage flows to the primary side of the step down transformer. The transformer's secondary side supplies 12 and 24 VAC to the Control Board.

Once powered, and provided that the Generator temperature is below 380° F (193° C), the Control Board calls for heat by supplying 10 - 15 VDC to the Solid State Relay terminals 3(+) 4(-). Once powered, the Solid State Relay closes terminals 1 and 2 which allows line voltage to flow to the Generator.

As the Generator begins to heat up, a type "K" thermocouple monitors the internal Generator temperature. As the heat continues to increase, so does the thermocouple's DC millivolts. Once the Generator's temperature rises to 380-420° F (193 - 215° C), the thermocouple is generating approximately 7.5 - 9.0 DC millivolts.

The Control Board receives these millivolts and proceeds to remove the 10 - 15 VDC to the Solid State Relay since the heating circuit has now become satisfied. Then, relay terminals 1 and 2 open, and the Generator stops heating.

When the Operate, Single Shot, or Start/Stop button is pressed, the Control Board is signaled to supply 24 VAC to the solenoid valve used in models MS-250/255 or the water pump used in models MS-150/155/355 for a split second.

The solenoid valve opens, or the water pump runs, and allows a shot of water (approximately 25ml or 3-4 table-spoons) to flow onto the generator surface for steaming.

NOTE: If the display is in a Timed Cycle (counting down), the Control Board will continue to activate the solenoid valve or water pump for repeated shots of water, once every 20 seconds, and for the duration of the cycle time displayed. See the Programming section of this manual for more information.

Since the Generator Cover is secured in place with a wing nut, the steam is forced downward through the Generator Steam Ports and onto the product. The Control Board's parameters can be custom programmed for the over all cycle steam time (CYC), as well as the interval time in seconds (SHO) when each shot of water occurs, and also the water volume (H2O) used per each shot of water. This Control Board also incorporates several Status Indicator LEDs. See the Operating and Programming sections of this manual).

An audio signal will sound for 3 seconds at the end of a Time Cycle. If the heating circuit continues to call for heat and the Generator overheats, a manual, resettable Hi-Limit Thermostat will trip and open the generator circuit.

TROUBLESHOOTING

⚠ WARNING ⚠

To avoid possible personal injury and/or damage to the unit, inspection, test and repair of electrical equipment should be performed by qualified service personnel. The unit should be unplugged when servicing, except when electrical tests are required.

Problem	Possible Cause	Corrective Action
Control Display is Blank (power On/Off switch is On but indicator light is off).	The power cord is not correctly plugged in.	Plug the power cord into the appropriate outlet.
	The power cord and/or electrical plug is damaged.	Inspect electrical wire, plug, and receptacle.
	The main electrical panel circuit breaker is off or has been tripped.	Reset circuit breaker. Contact your maintenance person or Authorized Service Agency if it trips again.
	Switch is inoperable.	Contact your maintenance person or Authorized Service Agency for service.
Control Display is blank (power On/Off switch is on and indicator light is on).	Control Board is inoperable	Contact your maintenance person or Authorized Service Agency for service.
	Transformer is inoperable.	
	Loose, burnt, or broken wires in circuit.	
Unit does not heat up (Control Display is on)	Hi-Limit Thermostat is tripped or inoperable.	Reset the Hi-Limit Thermostat according to the Operations section of this manual. If the Hi-Limit Thermostat requires continuous resetting, contact your Authorized Service Agency for service.
	Solid State Relay is inoperable.	
	Thermocouple is inoperable.	
	Control Board is inoperable.	
	Steam Generator is inoperable.	
	Loose, burnt, or broken wires in circuit.	
The unit's main electrical panel circuit breaker trips.	Damaged receptacle, plug, or cord; a loose connection or an internal component failure.	Turn the unit off, allow it to cool to room temperature, and then restart the unit. Contact your maintenance person or Authorized Service Agency if the condition repeats.
Water leaking inside electrical housing.	Pinhole leak in rubber hoses (MS-150/155/355).	Replace hoses.
	Loose or damaged water line tubes and/or fittings inside electrical housing.	Tighten or replace tubes and/or fittings.
"ERR" appears in the Control Display.	Programming and/or SHO and H2O values were adjusted/changed improperly.	Reset the Control Board as described in the Programming section of this manual. See Fault Codes.

TROUBLESHOOTING (continued)

Problem	Possible Cause	Corrective Action
Unit heats but there is little or no steam produced and/or The product requires more steaming than usual.	Water Line Valve is closed (MS-250/255).	Check that the Water Line Valve is Open
	Filter Strainer is restricted.	Check and clean the Filter Strainer as described in the Maintenance section of this manual.
	Quick disconnect is not fully engaged at rear of the unit or is damaged (MS-250/255).	Remove and reengage the Quick Disconnect firmly until a “click” is heard. Replace if damaged.
	Low or no water pressure in the water line (MS-250/255).	Remove the Quick Disconnect Insert from the rear of the unit. While holding over an empty cup, press the white plastic tip. Strong, steady water flow should be noted. If so, reengage firmly into unit. If not present, or pressure is low, contact your maintenance person or plumber.
	Improper water pressure to unit (MS-250/255).	Verify that a Water Pressure Regulator is installed and set to 20-25 PSI.
	Unit is not being cleaned properly (daily/monthly).	Clean unit daily and monthly as described in the Maintenance section of this manual.
	Programming and/or SHO, H2O values were adjusted/changed improperly.	Reprogram the SHO and H2O values as described in the Programming section of this manual.
	Insufficient or excessive calcium/mineral deposits on the Generator surface.	Verify that thin layer of calcium/mineral deposits is present on the Generator surface. Refer to the Maintenance section of this manual.
	Generator surface is bare.	Generator surface must have a thin calcium/mineral coating for proper steaming. Refer to the Maintenance section of this manual.
	Generator Steam Ports are restricted.	Clean the Steam Ports as described in the Maintenance section of this manual.
	Generator Cover is warped or loose.	Verify that the Generator Cover wingnut is tight. If noticeable steam escapes around the Generator Cover, replace the cover.
	Generator Diffuser is missing.	Install Generator Diffuser or replace if missing.
Excessive condensation in Food Compartment.	Water pressure is too high (MS-250/255).	Verify that the Water Pressure regulator is set to 20 - 25 PSI. Adjust accordingly.
	Programming and or SHO and H2O values were adjusted improperly.	Reprogram the SHO and H2O values as described in the Programming section of this manual.
Steam coming out around top covers or sides.	Generator Cover’s wingnut is loose.	Tighten wingnut.
	Generator Cover is warped.	Replace Generator Cover.

TROUBLESHOOTING (continued)

Problem	Possible Cause	Corrective Action
Unit floods overnight and/or continues to steam even when in idle mode.	Solenoid Valve is leaking due to debris trapped inside the plunger (MS-250/255).	Attempt to flush the debris out of the valve by rapidly operating the unit on a number of "single shot" cycles and then letting it rest. If the unit still leaks, disassemble the Solenoid Valve and clean out the plunger. Reassemble unit and test. If a leak is still present, replace the Solenoid Valve. Contact your maintenance person or Authorized Service Agency.
	Solenoid Valve is installed incorrectly (MS-250/255).	If the Solenoid Valve was replaced, verify that the "IN" and "OUT" labels on the valve correspond to the water flow.
	There is no pre-strainer or filter on the water line just before the unit (MS-250/255).	Equipment was supplied with a strainer. If missing, install strainer.

REPLACEMENT PARTS

MS-150/155/250/255 NOTE: Refer to parts list on page 25.

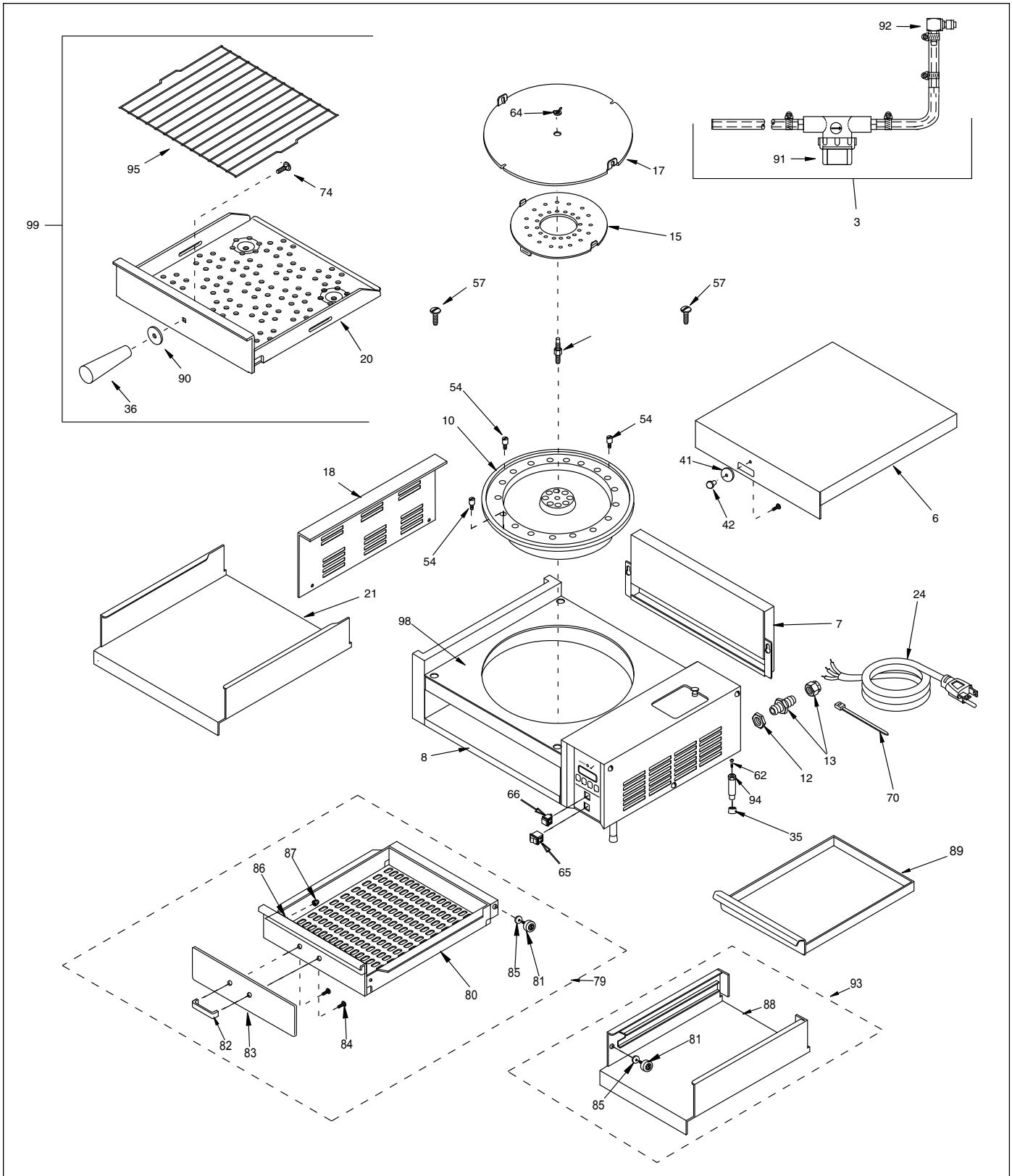

REPLACEMENT PARTS (continued)

MS-150/155 Service Compartment

NOTE: Refer to parts list on page 25.

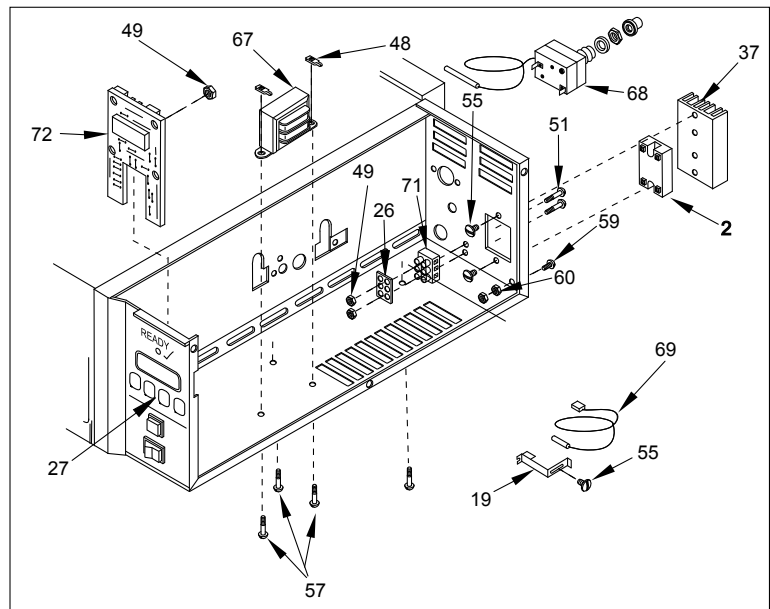
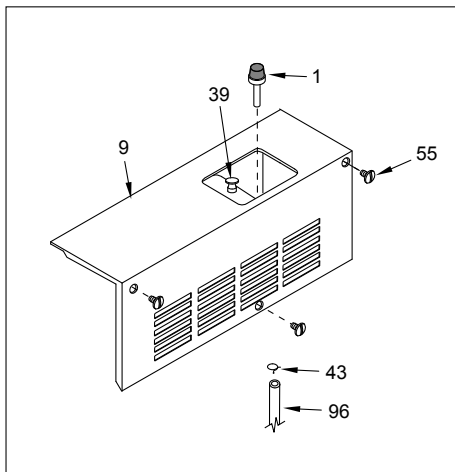
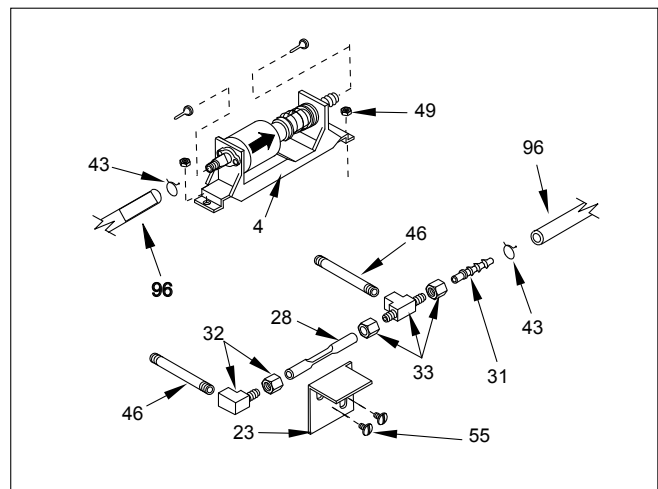
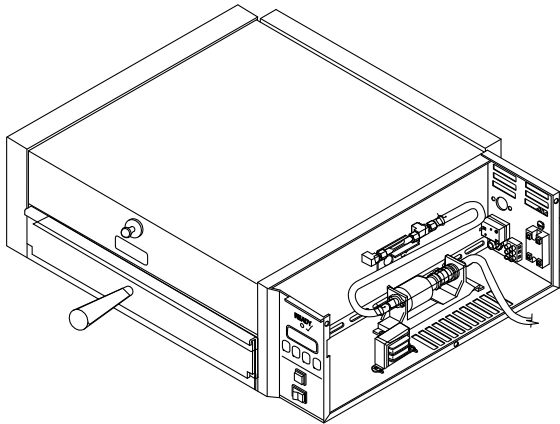

REPLACEMENT PARTS (continued)

MS-250/255 Service Compartment

NOTE: Refer to parts list on page 25.

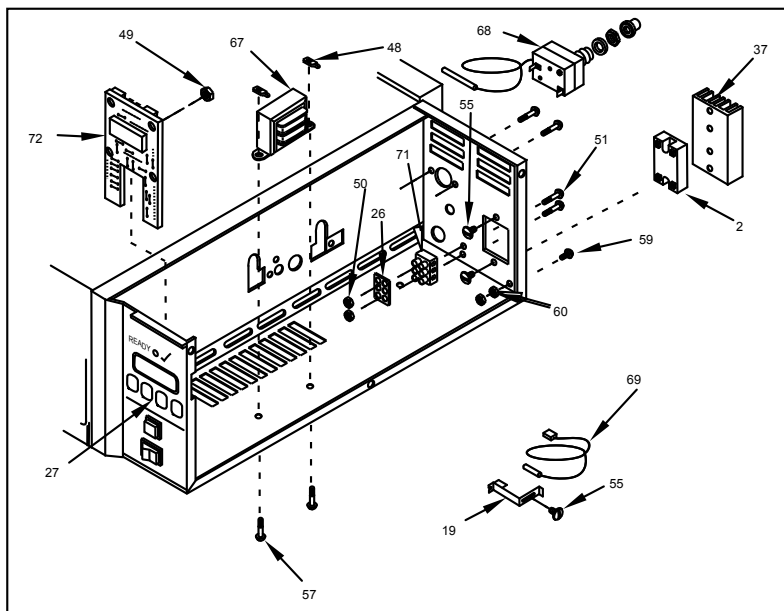
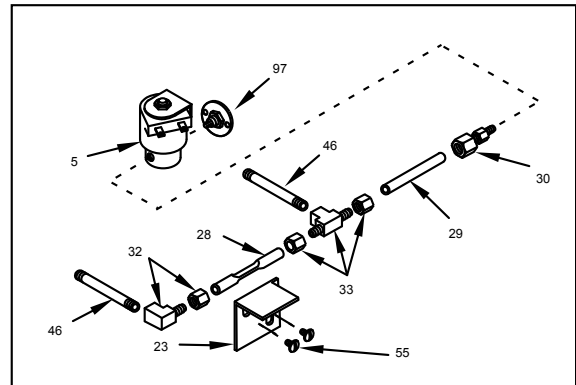
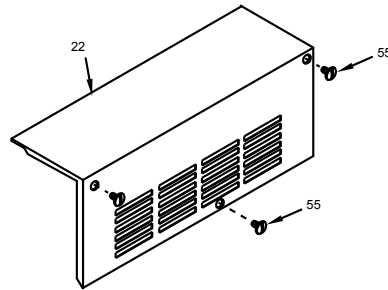
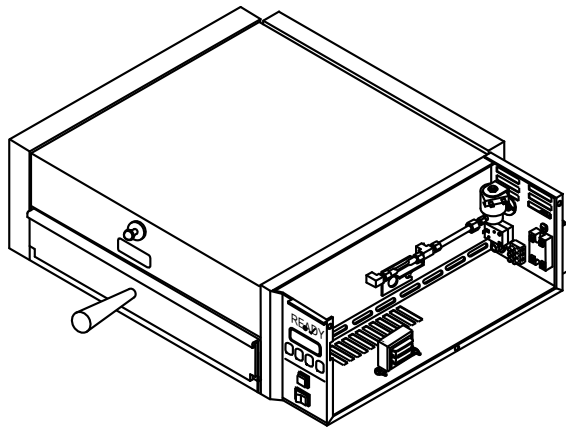

REPLACEMENT PARTS (continued)

MS-150/155/250/255

Item	Part No.	Description	Qty.
1	0010159	Filter Assy., Water Tank (MS-150/155)	1
2	7000652	Relay	1
3	0010584	Inlet Hose Assy. w/ strainer (MS-250/255)	1
4	7000137	Pump/Tube Assy., 24VAC (MS-150/155)	1
5	4040145	Solenoid Valve 24VAC (MS-250/255)	1
6	7000237	Top Cover Assy. (Includes #41 & #42)	1
7	0011314	Steam Vent Assy.	1
8	0021131	Floor/Chassis Weldment	1
9	0021179	Access Cover Weldment (MS-150/155)	1
10	7000246	Generator, 230V	1
	7000245	Generator, 208V	1
	7000300	Generator, 120V	1
11	0300129	Stud, Cover Hold Down	1
12	040P138*	Locknut, 1/2"	1
13	040K251	Strain Relief (includes #12)	1
14	05P2199*	Spacer	2
15	0503431	Diffuser, Steam	1
17	0503433	Cover, Generator	1
18	0503434	Cover, End Housing	1
19	0503435	Retainer, Thermocouple	1
20	0503988	Spatula MS-150/250	1
21	0021314	Liner, Cavity (MS-150/250)	1
22	0503441	Access Cover (MS-250/255)	1
23	0503472	Bracket, Hi-Limit Support	1
24	0700452	Power Cord, NEMA 6-20P	1
	0700453	Power Cord, CEE 7/7	1
	0700463	Power Cord, Nema 5-15P	1
26	100P967	Label, Marking	1
27	1001036	Label, Control Panel	1
	1001102	Label, Control Panel (MS-150/250 Mfg. # 9100432, 433, 424, & 439)	1
28	2000203	Tube, Restrictor, 1/4"	1
29	2000207	Tube, Inlet, 1/4 x 2-1/2" Long (MS-250/255)	1
30	2040103	Connector, Male, 1/4 x 1/8 NPT (MS-250/255)	1
31	2040106	Adapter, Tube/Hose (MS-150/155)	1
32	2040145	Elbow, Female, 1/8" x 1/4"	1
33	2040146	Tee, Female, 1/8" x 1/4"	1
35	210K108	Foot, Rubber (4 Pack)	1
36	2100119	Handle, Spatula (MS-150/250 only)	1
37	4050180	Heat Sink	1
39	2100170	Knob, Chrome (MS-150/155)	1
41	2100249	Guard, Knob	1

Item	Part No.	Description	Qty.
42	2100273	Knob	1
43	211P101	Clamp, Hose, 3/8 (MS-150/155)	1
44	211P103	Clamp, Hose, 1/2" (MS-150/155)	1
46	7000449	Generator Tube, 4-1/2" Lg. (MS-250/255)	1
	7000446	Generator Tube, 3-5/8" (MS-150/155)	2
48	300P102*	Nut, Speed, "U", #8-32	2
49	304P105*	Nut, Hex, KEPS, #4-40, Zinc	4
50	306P101*	Nut, Hex, #6-32	2
51	306P105*	Screw, Machine, #6-32 x 1/2"	2
52	306P123*	Screw, Machine, #6-32 x 7/8"	2
53	306P130*	Nut, Hex, KEPS, #6-32	2
54	306P134*	Screw, Machine, #6-32 x 3/8	3
55	308P103*	Screw, Machine, #8-32 x 1/4"	6
57	308P105*	Screw, Machine, #8-32 x 1/2"	4
58	308P120*	Screw, Machine, #8-32 x 5/8" (sltrshd)	4
59	308P124*	Screw, Machine, #8-32 x 1/2" (one-way)	1
60	308P143*	Nut, Hex, KEPS, #8-32	2
61	310P136*	Screw, Machine, #10-32 x 1-1/4" (splanhd)	4
62	310P149*	Screw, Machine, #10-32 x 7/8"	2
63	310P149*	Screw, Machine, #10-32 x 7/8" (MS-150)	2
64	325P170*	Nut, Wing, 1/4-20	1
65	4010137	Rocker Switch, Power On/Off 250V	1
	4010151	Rocker Switch, Power On/Off 120V	1
66	4010166	Switch, Momentary (GREEN)	1
	4010190	Switch, Momentary (WHITE) (for Mfg #9100432, 433, 424, & 439)	1
67	7000319	Transformer, 115-230/24V	1
68	7000135	Thermostat, Hi-Limit	1
69	4050214	Thermocouple, Type-K	1
70	406P107	Cable Tie	3
71	7000136	Terminal Block, 3-Pole	1
72	7000317	Control Board, Temperature/Timer, 24V, 50/60 Hz	1
74	338P102*	Bolt, Handle Mounting (MS-150/250 only)	1
79	0011471	Drawer Assy. (Incl. #80-87) (MS-155/255 only)	1
80	0021283	Drawer Weldment (MS-155/255 only)	1
81	210K195	Bearing, Roller, SS (MS-155/255 only) Incl. #85	4

REPLACEMENT PARTS (continued)

MS-150/155/250/255 (continued)

Item	Part No.	Description	Qty.
82	2100257	Handle (MS-155/255 only)	1
83	2100264	Guard, Handle (MS-155/255 only)	1
84	325P132*	Screw, Machine, 1/4-20 x 1/2" (MS-155/255 only)	2
85	05P2991	Spacer (MS-155/255 only)	2
86	306P137*	Stud, PEM, #6-32 x 3/8" (MS-155/255 only)	2
87	306P107*	Acorn Nut, #6-32 (MS-155/255 only)	2
88	0021237	Liner Weldment (MS-155/255 only)	1
89	0503536	Drip Pan	1
90	2100118	Guard, Handle	1
91	See page 29 for Strainer Parts Identification.		

Item	Part No.	Description	Qty.
92	7000139	Quick Disconnect Insert (MS-250/255)	1
93	0011413	Liner Assy. (MS-155/255)	1
94	0011370	2" Leg Kit (Incl. #35)	4
94a	210K134	4" Leg Kit (not shown)	1
94b	210K123	4" Leg Kit (optional) (not shown)	1
95	0800359	Trivet, Spatula MS-150/250	1
96	7000134	Silicon Tube Kit, Water Pump (MS-150/155)	1
97	7000138	Quick Disconnect Female Kit	1
98	0503429	Support, Generator Upper.	1
99	7000320	Spatula Kit (incl. #20, 36, 74, 90, 95) MS-150/250	1
* Only available in quantities of 10.			

REPLACEMENT PARTS (continued)

MS-355 Service Compartment

NOTE: Refer to parts list on page 28.

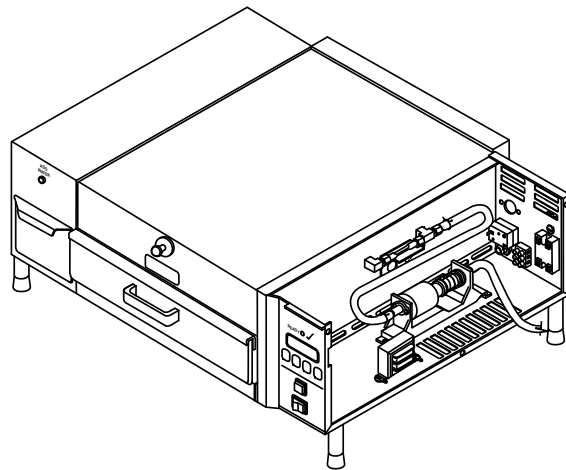

INSET A (Model MS 355)

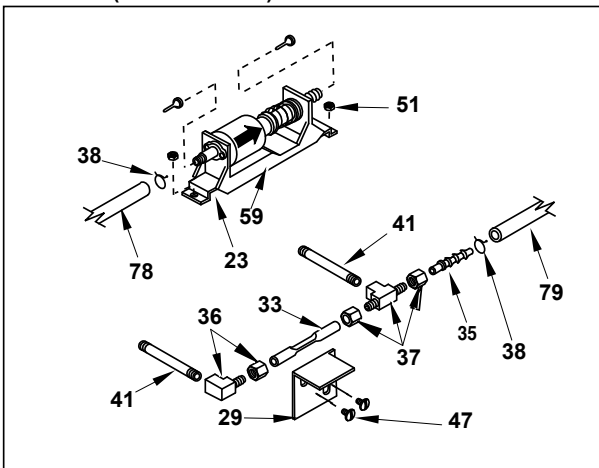

INSET B (Model MS 355)

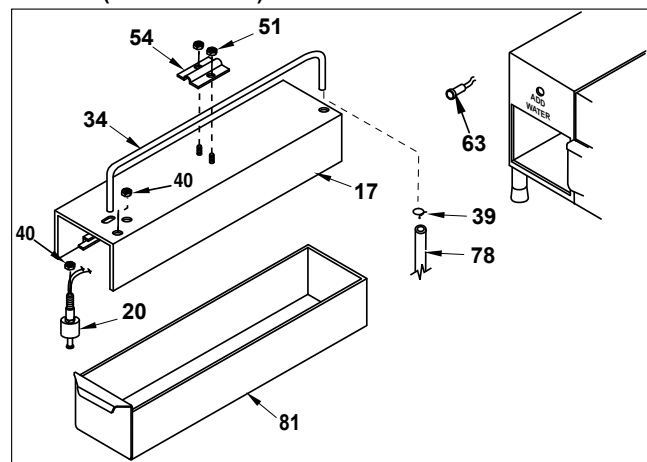

INSET C (Model MS 355)

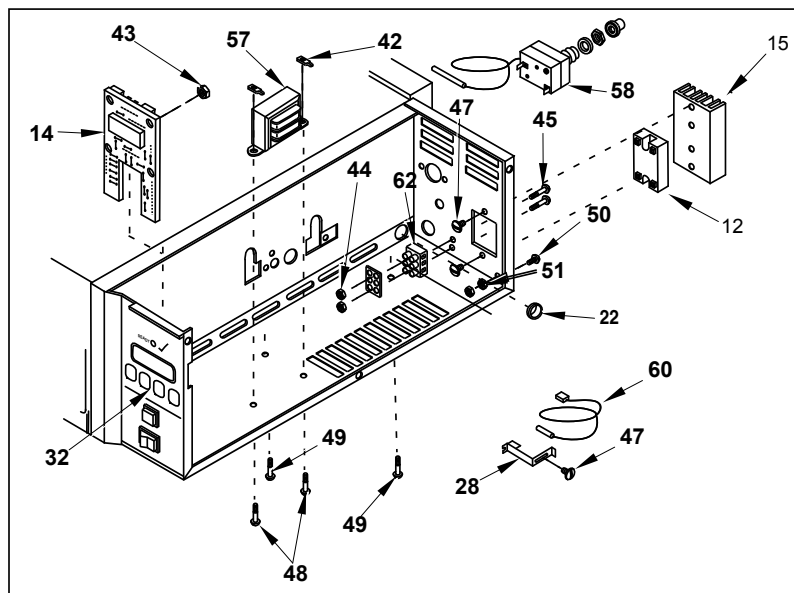

REPLACEMENT PARTS (continued)

MS-355

NOTE: Refer to parts list on page 28.

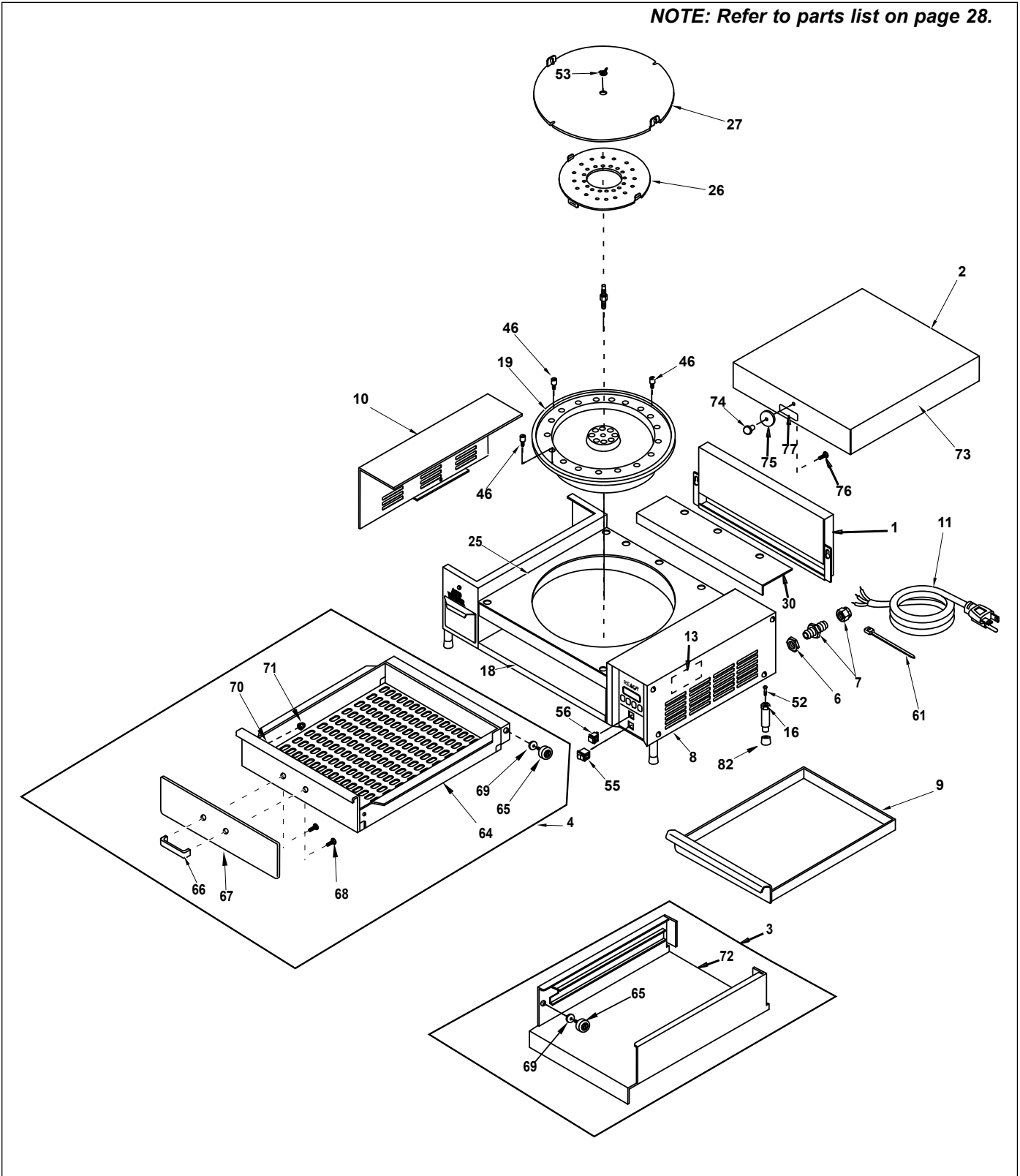

REPLACEMENT PARTS (continued)

MS-355

Item	Part No.	Description	Qty.
1	0011314	Steam Vent Assy.	1
2	7000237	Top Cover Assy. (Incl. #73-77)	1
3	0011413	Liner Assy. (Incl. #65, 69, 72)	1
4	0011471	Drawer Assy. (Incl. #64-71)	1
6	040P138	Locknut, Conduit, 1/2"	1
7	040K251	Strain Relief (includes #6)	1
8	0503441	Cover, Access	1
9	0503536	Drip Pan, Water	1
10	0503712	Cover, Tank Housing	1
11	0700452	Power Cord, NEMA 6-20P 250v	1
	0700463	Power Cord, 5-15P 120V	1
12	7000652	Relay	1
13	1001066	Label, Wiring Diagram	1
14	7000317	Control Board, 24V, 50/60 Hz	1
15	4050180	Heat Sink	1
16	0011370	Leg Assy., 2"	4
17	0021241	Channel Weldment	1
18	0021242	Floor/Chassis Weldment	1
19	7000245	Generator, 208V	1
	7000246	Generator, 230V	1
	7000300	Generator, 120V	1
20	0011447	Float Switch Assy.	1
21	0300129	Stud, Cover	1
22	040P119	Bushing, Shorty, 3/8"	4
23	0500281	Bracket, Pump Mounting	2
24	05P2199	Spacer	2
26	0503431	Diffuser	1
27	0503433	Cover, Generator	1
28	0503435	Retainer, Thermocouple	1
29	0503472	Bracket, Hi-Limit Thermostat Support	1
30	0503713	Guard, Wire	1
31	0700600	Wire Set (not shown) Float Switch	1
32	1001036	Label, Control Panel	1
33	2000203	Tube, Restrictor, 1/4"	1
34	2000208	Tube, Supply	1
35	2040106	Adapter, Tube/Hose	1
36	2040145	Elbow, Female, 1/8" x 1/4"	1
37	2040146	Tee, Female, 1/8" x 1/4"	1
38	211P101	Clamp, Hose, 3/8"	2
39	211P103	Clamp, Hose, 1/2"	2
40	218P112*	Nut, Nylon, 1/2-13	2
41	7000446	Pipe, 3-5/8" Long	2
42	300P102*	Nut, Speed, "U", #8-32	2

Item	Part No.	Description	Qty.
43	304P105*	Nut, Hex, KEPS, #4-40, Zinc	4
44	306P101*	Nut, Hex, #6-32	2
45	306P123*	Screw, Machine, #6-32 x 7/8"	2
46	306P134*	Screw, Machine, #6-32 x 3/8"	3
47	308P103*	Screw, Machine, #8-32 x 1/4"	20
48	308P105*	Screw, Machine, #8-32 x 1/2"	4
49	308P120*	Screw, Machine, #8-32 x 5/8"	2
50	308P124*	Screw, Machine, One-Way, #8-32 x 1/2"	1
51	308P143*	Nut, Hex, KEPS, #8-32	8
52	310P110*	Screw, Machine, #10-32 x 1/2", SS	4
53	325P170*	Wingnut, 1/4-20	1
54	0500229	Retainer	1
55	4010137	Switch, Rocker 250V	1
	4010151	Switch, Rocker 120V	1
56	4010166	Momentary Switch (Green)	1
57	7000319	Transformer, 115-230/24V	1
58	7000135	Thermostat, Hi-Limit	1
59	4040144	Water Pump, Oscillating, 24V	1
60	4050214	Thermocouple, Type-K	1
61	406P107*	Cable Tie, 1/8" Wide x 5" Long	3
62	7000136	Terminal Block, 3-Pole	1
63	4060371	Indicator Light, Blue, 12V	1
64	0021283	Drawer Weldment	1
65	210K195	Bearing, Roller, Nylon, SS (includes #69)	4
66	2100257	Handle	1
67	2100264	Guard, Handle	1
68	325P132*	Screw, Machine, 1/4-20 x 1/2"	2
69	05P2291	Spacer	2
70	306P137*	Stud, PEM, #6-32 x 3/8"	2
71	306P107*	Acorn Nut, #6-32	2
72	0021237	Liner Weldment	1
73	0503686	Cover, Top	1
74	2100273	Knob	1
75	2100249	Guard, Knob	1
76	390P101*	Bolt, M8 x 1.25 x 14mm Long	1
77	100P864	Label, Caution HOT	1
78	0011446	Silicone Tube Assy., 26"	1
79	0021358	Silicone Tube Assy., 17"	1
81	0011415	Water Tank Assembly	1
82	210K108	Foot, Rubber (4 Pack)	1

*** Only available in quantities of 10.**

REPLACEMENT PARTS (continued)

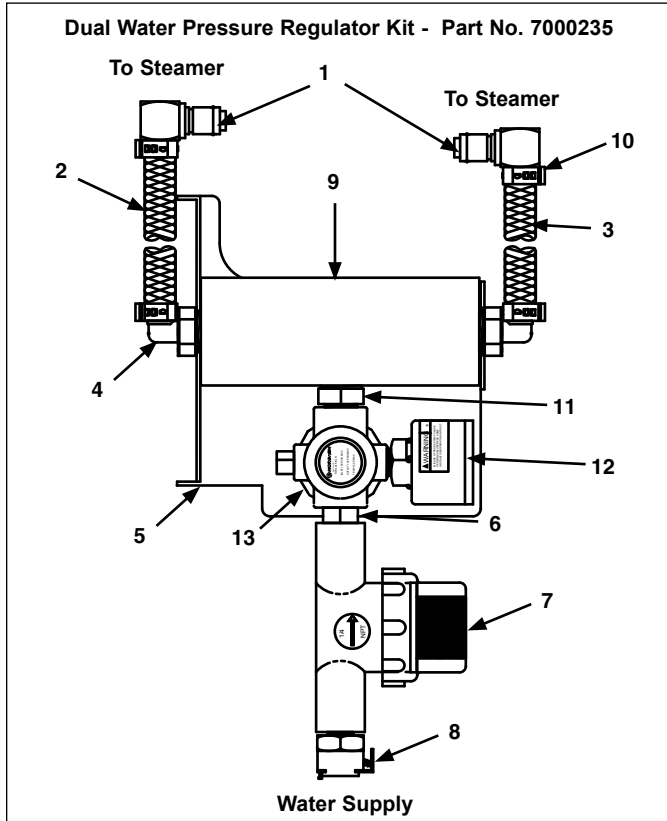

Item	Part No.	Description	Qty.
1	7000139	Elbow, Quick Disconnect - 1/4"	2
2	2030126	Tubing 1/4" I.D. PVC BRD. 24" Long	1
3	2030125	Tubing 1/4" I.D. PVC BRD. 12" Long	1
4	2040150	Elbow, Male - Nylon 1/4" Barb x 3/8" NPT	2
5	0503615	Bracket, Manifold Mtg.	1
6	2190129	Nipple 1/4" NPT x 1/4" NPT	1
7	7000333	Strainer - 1/4" FPT	1
8	2080118	Quick Disconnect - 1/8" NPT	1
9	2190113	Manifold	1
10	2110160	Clamp, Ear Med.	4
11	2040151	Nipple, HEX - 3/8" x 1/4" NPT Nylon	1
12	7000306	Gauge, Water Pressure	1
13	2170113	Regulator, Pressure	1

IMPORTANT: Two adjacent steamers can be fed with a dual water pressure regulator.

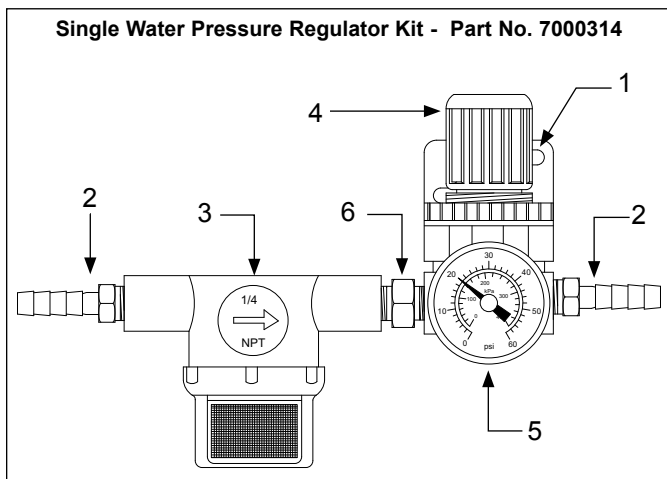

Item	Part No.	Description	Qty.
1	0503849	Bracket	1
2	2040130	Male Adapter, Barbed 1/4"	2
3	See Below for Strainer Parts Identification		
4	2170113	Regulator, Pressure	1
5	7000306	Gauge, Water Pressure	1
6	2190129	Nipple, 1/4" NPT x 1/4" NPT	1
7	2110104	Clamp, Worm (not shown)	2

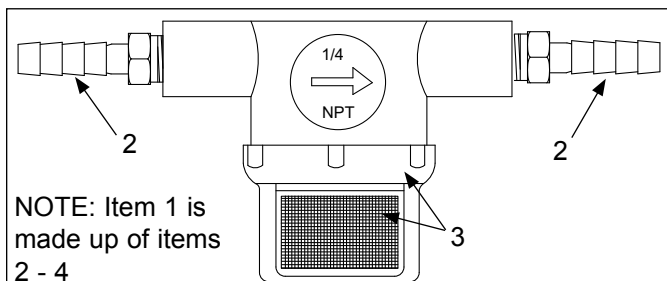

Item	Part No.	Description	Qty.
1	7000333	Water Line Strainer Kit	1
2	2040130	Male Adapter, Barbed 1/4"	2
3	7000334	Replacement Screen and O-ring kit	1
4	2110104	Clamp, Worm (not shown)	2

WIRING DIAGRAMS

MS-150/155/250/255

NOTE: ALL WIRES TO BE 14 GA. AWM-105°C
UNLESS OTHERWISE SPECIFIED.
18 GA. AWM-105°C
• 22 GA. AWM-105°C

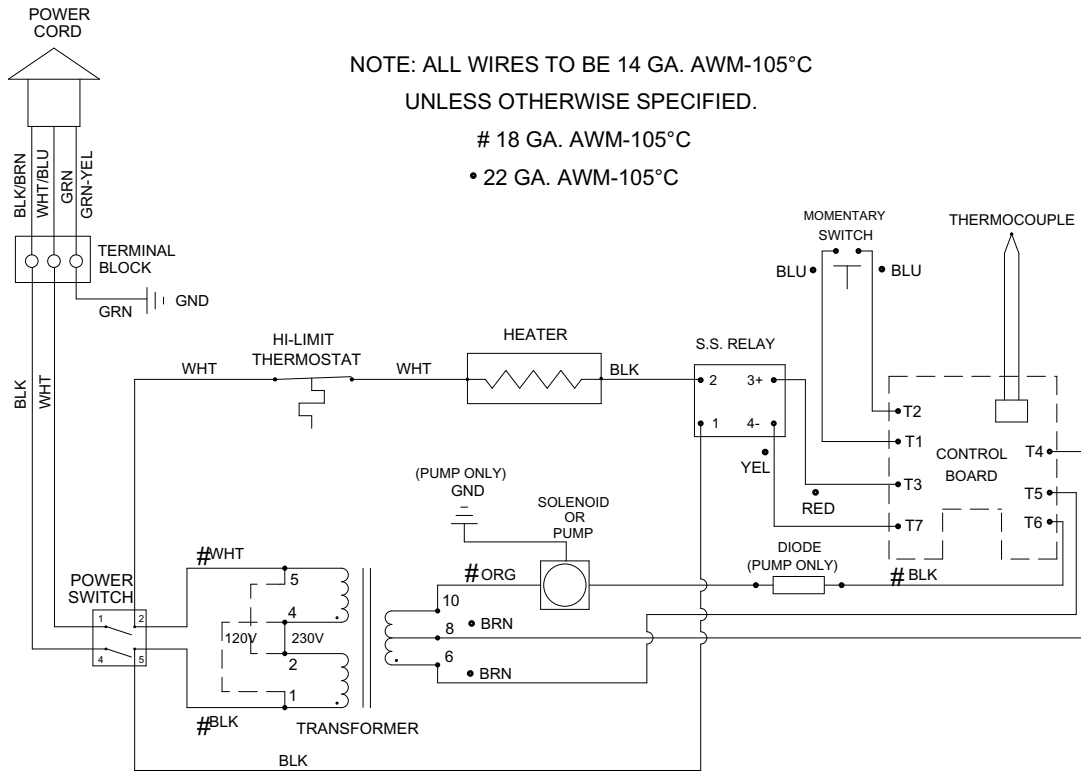

MS-355

NOTE: ALL WIRES TO BE 14 GA. AWM-105°C
UNLESS OTHERWISE SPECIFIED.
18 GA. AWM-105°C
• 22 GA. AWM-105°C

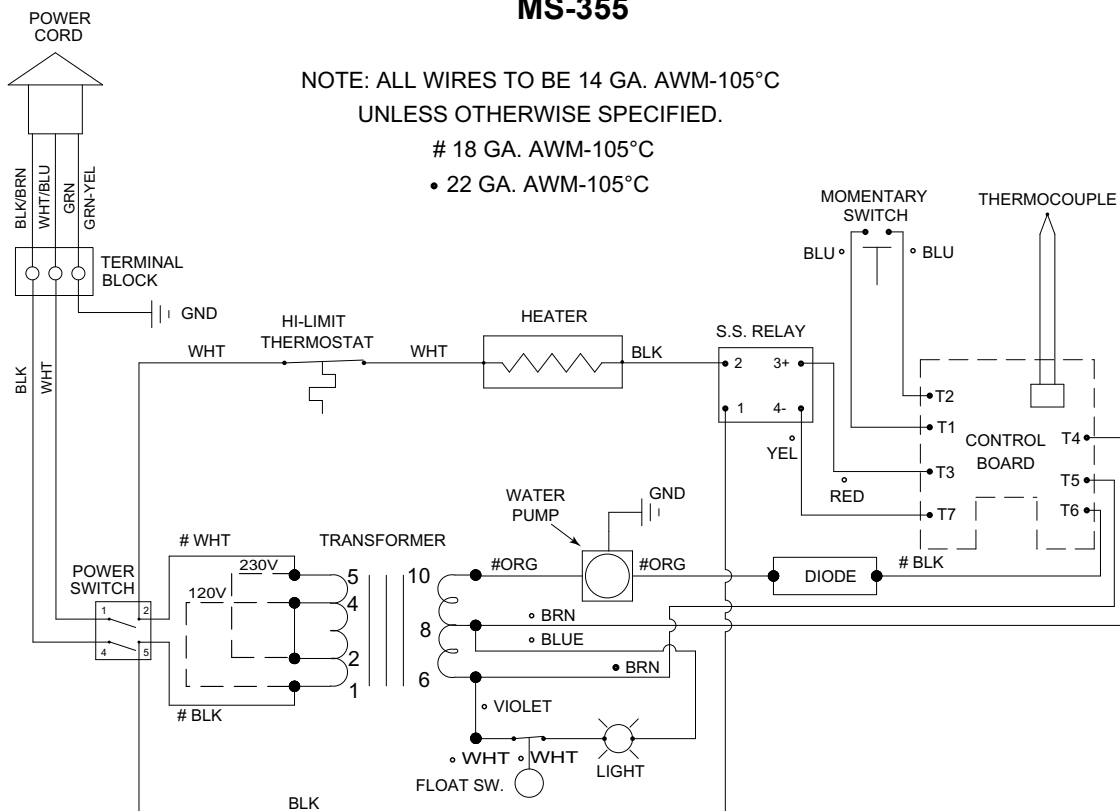

LIMITED WARRANTY

Equipment manufactured by Roundup Food Equipment Division of A.J. Antunes & Co. has been constructed of the finest materials available and manufactured to high quality standards. These units are warranted to be free from electrical and mechanical defects for a period of one (1) year from date of purchase under normal use and service, and when installed in accordance with manufacturer's recommendations. To insure continued operation of the units, follow the maintenance procedures outlined in the Owner's Manual. During the first 12 months, electro-mechanical parts, non-overtime labor, and travel expenses up to 2 hours (100 miles/160 km), round trip from the nearest Authorized Service Center are covered.

1. This warranty does not cover cost of installation, defects caused by improper storage or handling prior to placing of the Equipment. This warranty does not cover overtime charges or work done by unauthorized service agencies or personnel. This warranty does not cover normal maintenance, calibration, or regular adjustments as specified in operating and maintenance instructions of this manual, and/or labor involved in moving adjacent objects to gain access to the equipment. This warranty does not cover consumable/wear items. This warranty does not cover damage to the Load Cell or Load Cell Assembly due to abuse, misuse, dropping of unit/shock loads or exceeding maximum weight capacity (4 lbs). This warranty does not cover water contamination problems such as foreign material in water lines or inside solenoid valves. It does not cover water pressure problems or failures resulting from improper/incorrect voltage supply. This warranty does not cover Travel Time & Mileage in excess of 2 hours (100 miles/160 km) round trip from the nearest authorized service agency.
2. Roundup reserves the right to make changes in design or add any improvements on any product. The right is always reserved to modify equipment because of factors beyond our control and government regulations. Changes to update equipment do not constitute a warranty charge.
3. If shipment is damaged in transit, the purchaser should make a claim directly upon the carrier. Careful inspection should be made of the shipment as soon as it arrives and visible damage should be noted upon the carrier's receipt. Damage should be reported to the carrier. This damage is not covered under this warranty.
4. Warranty charges do not include freight or foreign, excise, municipal or other sales or use taxes. All such freight and taxes are the responsibility of the purchaser.
5. THIS WARRANTY IS EXCLUSIVE AND IS IN LIEU OF ALL OTHER WARRANTIES, EXPRESSED OR IMPLIED, INCLUDING ANY IMPLIED WARRANTY OR MERCHANTABILITY OR FITNESS FOR A PARTICULAR PURPOSE, EACH OF WHICH IS HEREBY EXPRESSLY DISCLAIMED. THE REMEDIES DESCRIBED ABOVE ARE EXCLUSIVE AND IN NO EVENT SHALL ROUNDUP BE LIABLE FOR SPECIAL CONSEQUENTIAL OR INCIDENTAL DAMAGES FOR THE BREACH OR DELAY IN PERFORMANCE OF THIS WARRANTY.



A.J. Antunes & Co.
Headquarters/Manufacturing
Carol Stream, Illinois 60188 USA
Phone: (630) 784-1000
Toll Free: (800) 253-2991
Fax: (630) 784-1650

Antunes Equipment
Manufacturing (Suzhou) Ltd.,
Suzhou, Jiangsu, China 215011
Phone: 86-512-6841-3637
Toll Free: 400-0-7878-22
Fax: 86-512-6841-3907

www.ajantunes.com