



HENNY PENNY®

Engineered to Last

**Henny Penny
Heated Holding Cabinet**

**Model HCN-5
Model HHC-136**

OPERATOR'S MANUAL

REGISTER WARRANTY ONLINE AT WWW.HENNYPENNY.COM

TABLE OF CONTENTS

Section		Page
Section 1.	INTRODUCTION	1-1
	1-1. Heated Holding Cabinet	1-1
	1-2. Features	1-1
	1-3. Proper Care	1-2
	1-4. Assistance	1-2
	1-5. Safety	1-2
Section 2.	INSTALLATION	2-1
	2-1. Introduction	2-1
	2-2. Unpacking	2-1
	2-3. Location	2-2
	2-4. Electrical Connection	2-2
	2-5. Cabinet Dimensions	2-3
Section 3.	OPERATION	3-1
	3-1. Introduction	3-1
	3-2. Operating Controls and Components	3-1
	3-3. Start-Up	3-3
	3-4. Operation with Product	3-4
	3-5. Cleaning Procedures	3-4
Section 4.	TROUBLESHOOTING	4-1
	4-1. Troubleshooting Guide	4-1
	GLOSSARY	G-1

Distributor List

SECTION 1. INTRODUCTION

1-1. HEATED HOLDING CABINET

The Henny Penny Heated Holding Cabinet is a basic unit of food processing equipment designed to hold hot foods at proper temperature in commercial food operations. This cabinet keeps hot foods humid while maintaining temperature.

NOTICE

As of August 16, 2005, the Waste Electrical and Electronic Equipment directive went into effect for the European Union. Our products have been evaluated to the WEEE directive. We have also reviewed our products to determine if they comply with the Restriction of Hazardous Substances directive (RoHS) and have redesigned our products as needed in order to comply. To continue compliance with these directives, this unit must not be disposed as unsorted municipal waste. For proper disposal, please contact your nearest Henny Penny distributor.



1-2. FEATURES

- Easily cleaned
- Adjustable, thermostatically controlled heat
- Lift-off doors
- Easy access to electrical components
- Moist heat
- Stainless steel construction
- Full perimeter magnetic door seals
- Lift out tray racks
- Glass door on one side and flip-up doors on control side

1-3. PROPER CARE

As in any unit of food service equipment, the Henny Penny Heated Holding Cabinet does require care and maintenance. Requirements for the maintenance and cleaning are contained in this manual and must become a regular part of the operation of the unit at all times.

1-4. ASSISTANCE

Should you require outside assistance, just call your local independent Henny Penny distributor in your area, call Henny Penny Corp. 1-800-417-8405 toll free or 1-937-456-8405, or go to Henny Penny online at www.hennypenny.com.

1-5. SAFETY

The only way to ensure safe operation of the Henny Penny Heated Holding Cabinet is to fully understand the proper installation, operation, and maintenance procedures. The instructions in this manual have been prepared to aid you in learning the proper procedures. Where information is of particular importance or is safety related, the words NOTICE, CAUTION, or WARNING are used. Their usage is described below.



SAFETY ALERT SYMBOL is used with DANGER, WARNING, or CAUTION which indicates a personal injury type hazard.



NOTICE is used to highlight especially important information.



CAUTION used without the safety alert symbol indicates a potentially hazardous situation which, if not avoided, may result in property damage.



CAUTION used with the safety alert symbol indicates a potentially hazardous situation which, if not avoided, may result in minor or moderate injury.



WARNING indicates a potentially hazardous situation which, if not avoided, could result in death or serious injury.

SECTION 2. INSTALLATION

2-1. INTRODUCTION

This section provides the installation instructions for the Henny Penny Heated Holding Cabinet.

NOTICE

Installation of this unit should be performed only by a qualified service technician.



Do not puncture the skin of the unit with drills or screws as component damage or electrical shock could result.

2-2. UNPACKING

The Henny Penny Heated Holding Cabinet has been tested, inspected, and expertly packed to ensure arrival at its destination in the best possible condition. The cabinet rests on cardboard pads that sit on a wooden skid. The racks inside the cabinet are secured with cardboard packing. The unit is then packed inside a heavy cardboard carton with sufficient padding to withstand normal shipping treatment.

NOTICE

Any shipping damages should be noted in the presence of the delivery agent and signed prior to his or her departure.

To remove the Henny Penny Heated Holding Cabinet from the carton, you should:

1. Carefully cut banding straps.
2. Lift the carton off the unit.
3. Lift the unit off the cardboard padding and skid.



Take care when moving the fryer to prevent personal injury. The unit weighs 110 lbs. (49.9kg).

4. Open doors and remove packing from behind racks.
5. Peel off any protective covering from the exterior of the cabinet.
6. The unit is now ready for location and set up.

2-3. LOCATION

The unit should be placed in an area where the doors can be opened without interruption and loading and unloading of product is easy. For proper operation, the cabinet must be level.



Figure 1

The unit **MUST** be mounted to the table-top, using the 4, 1/4-20 x 1-1/2 inch (38.1 mm) bolts and washers, supplied with the cabinet.

Screw the bolts up through the table and into the holes in the base of the unit as shown in Figure 1.

2-4. ELECTRICAL CONNECTION

The data plate, located on the side of the top module, will specify the correct electrical supply. The heated holding cabinet is available from the factory as a 120 or 240 VAC unit. The unit requires a grounded receptacle with a separate electrical line protected by a fuse or circuit breaker of the proper rating. For European markets, verify the electrical plug meets the proper electrical rating and country type. See local authorities for proper standards.



To avoid electrical shock, the cabinet must be adequately and safely grounded (earthed) according to local electrical codes.

Refer to the table below for electrical ratings.

Product Number	Volts	Watts	Amps
HHC-136	120	1320	
	240	1320	5.5
HCN-5	240	1320	5.5

2-5. CABINET DIMENSIONS

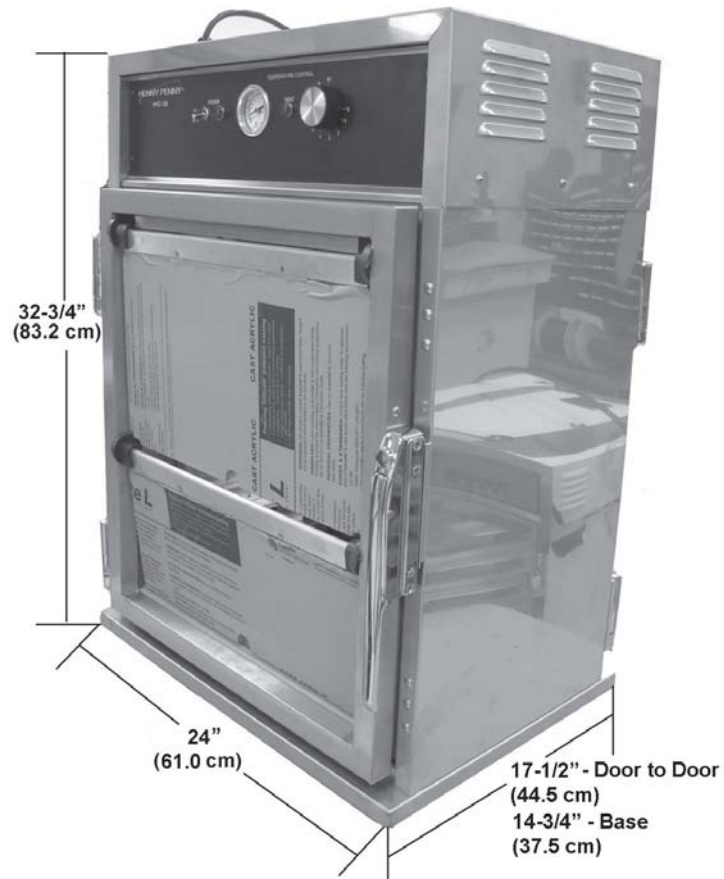

**Model HHC-136
&
Model HCN-5**

SECTION 3. OPERATION

3-1. INTRODUCTION

This section provides operating procedures for the heated holding cabinets. The Introduction, Installation and Operation Sections should be read, and all instructions should be followed before operating the cabinet.

3-2. OPERATING CONTROLS AND COMPONENTS

Figures 1 through 3 identify and describe the function of all the operating controls and the major components of the cabinet.

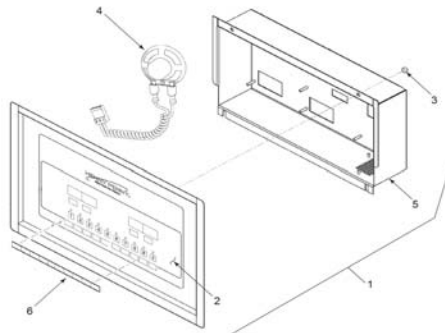

Figure 1

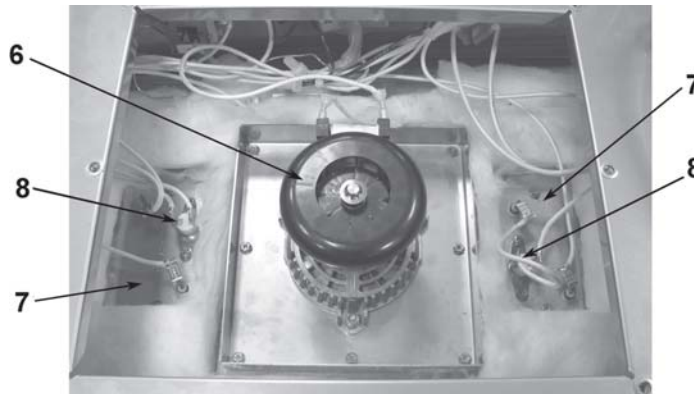

Figure 2

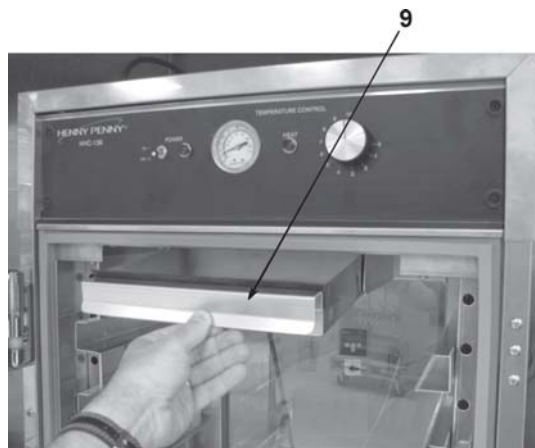

Figure 3

3-2. OPERATING CONTROLS AND COMPONENTS (Continued)

Fig. No.	Item No.	Description	Function
1	1	Power Switch	A toggle switch that switches electrical current to the unit
1	2	Thermometer	Indicates the air temperature inside the cabinet
1	3	Thermostat	An electromechanical device that controls the temperature inside the cabinet
1	4	Power Light	Illuminates when the power switch is in the ON position and the components are energized
1	5	Heat Light	Illuminates when the thermostat turns on the heaters
2	6	Blower Motor	Used to recirculate the hot humid air throughout the cabinet
2	7	Heater	Two, open-resistance, heaters that provides heat throughout the cabinet; 120V-600W
2	8	High Limit	A safety device mounted next to the heater which protects the unit from overheating
3	9	Water Pan	Holds the water for creating humidity in the cabinet

3-3. START-UP



Step 1



Step 2

NOTICE

Before using the heated holding cabinet, the unit should be thoroughly cleaned as described in the Cleaning Procedures Section of this manual.

1. To put the unit into operation, move the power switch to the ON position. The power light should now be illuminated and the blowers should be in operation.
2. Remove the water pan and put approximately 850 ml. of hot water in the pan. Return the pan to its location.

NOTICE

Be sure to push the water pan in as far as it will go so that it does not block air from the thermometer and thermostat capillary tubes. This will ensure proper operation of these components.

3. Set the thermostat at #8 or approximately 185°F (85°C). (Refer to KFC Standards Library.) When the heat light goes out, the unit is ready for operation.

NOTICE

The unit should take approximately 25-35 minutes to heat to temperature during start up. Be sure that the temperature light goes out before loading with product.

3-4. OPERATION WITH PRODUCT

1. Place the hot product on racks and insert between the cabinet racks.
2. Serve the product first that has been in the cabinet the longest.
3. In order to maintain a constant temperature, open the doors only as necessary to load and unload product.

3-5. CLEANING PROCEDURES

1. Turn all controls to the OFF position.
2. Disconnect the electrical supply to the cabinet.



To avoid burns, allow the unit to cool before cleaning.

3. Open the doors and remove all trays from the cabinet.
4. Take the trays to a sink and clean them thoroughly.
5. Remove the water pan and clean it with a soft cloth, soap, and water.
6. Wipe the control panel with a damp cloth. Do not splash water around the controls.
7. Clean the exterior of the cabinet with a damp cloth.



Step 8



Do not use steel wool, other abrasive cleaners or cleaners/sanitizers containing chlorine, bromine, iodine or ammonia chemicals, as these will deteriorate the stainless steel material and shorten the life of the unit.

Do not use a water jet (pressure sprayer) to clean the unit, or component failure could result.

8. Open the doors and remove side racks. Clean the racks with soap and water.
9. Clean the interior of the cabinet thoroughly with a cloth and soap water.
10. Put the side racks and water pan back into the cabinet.
11. Leave at least one door open over night to allow the unit to thoroughly dry out.

SECTION 4. TROUBLESHOOTING

4-1. TROUBLESHOOTING GUIDE

Problem	Cause	Correction
Product not holding temperature	<ul style="list-style-type: none"> • Doors are left open • Thermostat set too low • Gasket torn or worn • Product held too long 	<ul style="list-style-type: none"> • Keep doors closed except to load and unload product • Increase thermostat setting by moving the knob to a higher number setting • Replace gasket • Hold product only for recommended time
Cabinet steaming - product becoming soggy	<ul style="list-style-type: none"> • Holding product too long 	<ul style="list-style-type: none"> • Hold product for recommended time
Product dry	<ul style="list-style-type: none"> • No water in pan 	<ul style="list-style-type: none"> • Remove pan and add approximately 850 ml. of hot water
Unit will not heat to desired temperature	<ul style="list-style-type: none"> • Thermometer not indicating true temperature • Doors being left open too much • Gasket torn or worn 	<ul style="list-style-type: none"> • Check cabinet temperature with another thermometer; have thermometer replaced if necessary • Only open doors as necessary • Replace gasket

NOTICE

More detailed troubleshooting information is available in the Technical Manual, available at www.hennypenny.com, or 1-800-417-8405 or 1-937-456-8405.

GLOSSARY

HENNY PENNY HOLDING CABINETS

air temperature probe	a round device located inside the cabinet that measures the inside air temperature and sends that information to the control panel
concentration ring assembly	a metal assembly located in the water pan in the bottom of the unit that helps keep an even humidity level inside the cabinet
clean water pan setpoint	a preset temperature at which a sensor warns the operator that the water pan has excessive lime deposits
control panel	the components that control the operating systems of the unit; the panel is located on the top front surface of the cabinet
deliming agent	a cleaner used to remove lime deposits in the water pan
drain valve	a device that lets the water drain from the water pan into a shallow pan on the floor; the valve should be closed while the unit is in use if humidity is desired
float switch	a device that senses low water levels in the water pan
food probe	a sensor located outside the cabinet that, when inserted into the product, communicates the temperature of the product to the control panel
food probe receptacle	the connection where the food probe is inserted in order to communicate with the control panel
humidity sensor	a device that measures the percentage of humidity inside the cabinet during use
humidity setting	a preset moisture level at which the cabinet operates; this setting is programmed at the factory but can be changed in the field
LED	an electronic light on the control panel
minimum holding temperature	the lowest temperature at which a food product can be safely held for human consumption
module	the removable top part of the cabinet that contains all of the operating system
out of water trip point	a preset temperature at which a sensor warns the operator that the water pan needs refilled
parameters	a preset group of setpoints designed for holding specific food products at certain temperature and humidity levels
power switch	the ON/OFF switch that sends electricity to the unit's operating systems; this switch does not disconnect the electrical power from the wall to the unit
pressure sprayer	a device that shoots a stream of water under pressure; this device should NOT be used to clean a holding cabinet

probe clip	a metal holder that attaches to the outside of the control panel to hold the food probe when not in use; the clip is an optional accessory
product load capacity	the highest recommended number of pounds/kilograms of food product that can be safely held in the cabinet
proof function	a program used for allowing bread to rise
relative humidity	the humidity level outside the cabinet
setpoint	a preset temperature or humidity; the setpoint is a programmable feature
system initialization	a programming process that resets factory settings
temperature setting	a preset temperature up to which the cabinet will heat; this setting is programmed at the factory but can be changed in the field
vent activation switch	an automatic control that opens and closes the vent on the rear of the cabinet to maintain the preset humidity level
vented panels	openings on the cabinet that allow air access on the sides and rear of the module
water fill line	the line marked on the inside of the water pan that shows the maximum water level to prevent overflow onto the floor
water heater sensor	a part in the water heater that sends a message to the controls when the water pan is limed up or empty
water jet	a device that shoots a stream of water under pressure; this type of device should NOT be used to clean a holding cabinet
water pan	the area in the cabinet that holds water for creating humidity inside the cabinet



Henny Penny Corporation
P.O. Box 60
Eaton, OH 45320

1-937-456-8400
1-937-456-8402 Fax

Toll free in USA
1-800-417-8417
1-800-417-8434 Fax

www.hennypenny.com

FM05-040-E Henny Penny Corp., Eaton, Ohio 45320, Revised 7-10-13