

Gold Standard Toaster

Model GST-2H Int'l Owner's Manual

Manufacturing Numbers:
9210961, 9210962, 9211004



Contents

Overview	2
Before Use	2
In Case of Damage	2
Service/Technical Assistance	2
Equipment Information to Save	2
Authorized Service Agency	2
Safety Information	3
Installation	3
Operation	3
Maintenance	3
Service	3
Specifications	4
Installation	5
Operation	5
Light/Dark Adjustments	5
User Mode	6
Error Codes	6
Manager Mode	6
Safety Features	6
Hi-Limit Control	6
Purging Buns from Toaster	6
Fault Messages	6
Default Settings	6
Daily Cleaning	7
Clean Toaster and Belt Wraps	7
Inspect the belts	7
Quarterly Cleaning	7
Remove Belt Wraps/Clean Rollers	7
Install Belt Wraps	8
Annual Cleaning	9
Clean Cooling Fans/Housings	9
Troubleshooting	10
Exploded Diagram 1	12
Exploded Diagram 2	13
Exploded Diagram 3	14
Replacement Parts	15
Wiring Diagram	17
Mfg No. 9210961	17
Mfg No. 9210962 & 9211004	18
Notes	19
Limited Warranty	20

Overview

The Antunes Gold Standard Toaster is an energy-efficient toaster designed with a dual belt feed for toasting crowns, heels, and clubs. The electronic temperature controller ensures proper calibration and event toasting. A continuously moving dual belt allows for immediate feeding of buns without sticking. The Gold Standard Toaster features a new design that saves valuable counter space and increases energy efficiency.

Before Use

This manual contains safety, installation, and operating procedures for the toaster. Read and understand it completely before installing or operating the toaster. Keep this document for reference. If the toaster changes ownership, this manual must accompany it.

In Case of Damage

If the toaster arrives damaged, file a claim with the carrier immediately. Save all packing materials when filing a claim. Freight damage claims are the responsibility of the purchaser and are not covered under warranty.

Website

www.antunes.com

Service/Technical Assistance

If any parts are missing or damaged, contact Antunes Customer Service immediately at +1-877-392-7856 (toll free).

If there are problems with the installation or operation of this product, contact Antunes Technical Service toll free at +1-877-392-7854.

Fill in the information in the next column and have it handy when calling for assistance. The serial number is on the specification plate located on the system.

Equipment Information to Save

Purchased from:

Date of purchase:

Model number:

Serial number:

Manufacturing number:

Authorized Service Agency

Name:

Phone No:

Address:

Safety Information

Installation

- Read and understand all instructions before installing or using the unit.
- Install and locate the equipment only for its intended use as described in this manual.
- All electrical connections must be in accordance with local electrical codes and any other applicable codes. The equipment must be grounded according to local electrical codes to prevent electrical shocks. It requires a grounded receptacle with separate electrical lines, protected by fuses or a properly-rated circuit breaker.
- Electrical ground is required on this appliance. Consult a qualified electrician if there is any uncertainty about whether the appliance is properly grounded.
- Do not modify the power supply cord plug. If it does not fit the outlet, have a proper outlet installed by a qualified electrician.
- Do not use an extension cord with this appliance.

Operation

- The toaster is furnished with a properly grounded cord connector. Do not attempt to defeat the grounded connector.
- Do not operate the toaster if it has been damaged or dropped, if it has a damaged cord or plug, or if it is not working properly.
- Do not block or cover any openings on the equipment.
- Do not immerse the cord or plug in water.
- Keep the cord away from heated surfaces.
- Do not allow the cord to hang over the edge of a table or counter.

Maintenance

- Do not use abrasive materials; they can damage the toaster's stainless steel finish.
- Do not use corrosive chemicals in this equipment.
- Chlorides or phosphates in cleaning agents (e.g., bleach, sanitizers, degreasers, and detergents) can permanently damage stainless steel equipment. The damage is usually in the form of discoloration, dulling of the metal surface finish, pits, voids, holes, or cracks. This damage is permanent and is not covered by warranty.
- Use only chemical cleaners that are safe for cast aluminum. Observe all precautions and warnings on product labels.
- Always use a soft, damp cloth for cleaning. Rinse with clear water and wipe dry. When required, always rub in the direction of metal polish lines.
- Routine cleaning should be performed daily with soap, ammonia detergent, and water.
- Rub off finger marks and smears using soap and water.
- Do not clean the toaster with a water jet.

Service

- Inspection, testing, and repair of electrical equipment must be performed only by qualified service personnel.
- Have the toaster serviced only by qualified personnel. Contact Antunes Technical Service for adjustment or repair.
- Turn the power off, unplug the power cord, and allow unit to cool to room temperature before performing any service or maintenance.
- If the supply cord is damaged, it must be replaced by the manufacturer, its service agent, or a similarly qualified person in order to avoid an electrical hazard.

Specifications

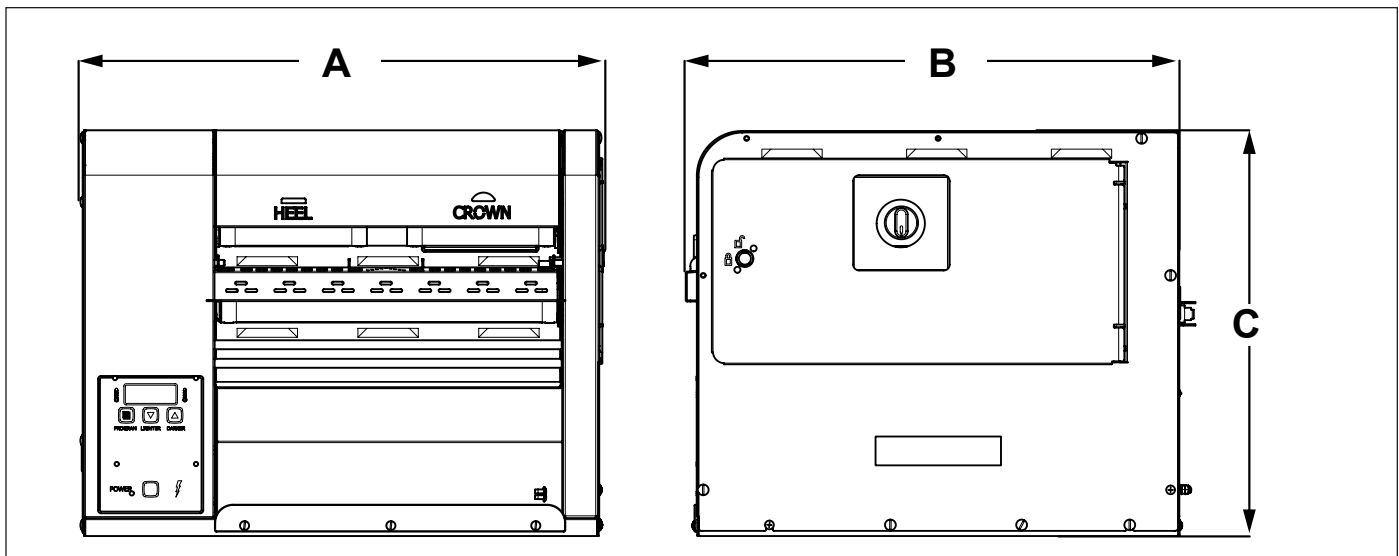

Model & Mfg. No.	Width (A)	Depth (B)	Height (C)
GST-2H 9210961	22" (559 mm)	21" (533 mm)	17" (432 mm)
GST-2H 9210962	22" (559 mm)	21" (533 mm)	17" (432 mm)
GST-2H 92110004	22" (559 mm)	21" (533 mm)	17" (432 mm)

Model & Mfg. No.	Volts	Watts	Hertz	Plug Description
GST-2H 9210961	230	2000	50/60	CEE 7/7, 16 Amp., 250 VAC (Assembly Only).
GST-2H 9210962	208	2000	60	NEMA 6-20P 20 Amp, 250 Volt Right Angle
GST-2H 9211004	208-240	2000	60	NEMA L6-15 15 Amp, 250 Volt

Installation

1. Remove unit and all packing materials from shipping carton.
 2. Open the Accessories Box. It should contain the following:
 - Bun Chute
 - Bun Feeder
 - 1 Belt Set
 - Owner's Manual
- NOTE:** If any parts are missing or damaged, contact Antunes Customer Service IMMEDIATELY at +1-877-392-7856 (toll free).
3. Open the side door (Figure 1) and remove all of the plastic ties securing the toaster mechanism.
 4. Remove all packing materials and protective coverings from the unit.
 5. Wipe the entire exterior of the toaster and the accessories mentioned above with a hot damp cloth. Allow to air dry

NOTE: Do NOT use a dripping wet cloth. Wring out before use.

6. Attach the Bun Chute, Bun Feeder, and Butter Wheel assembly.
7. Make sure the Compression Knob is set to 3, the default setting.

When placing the toaster into service, pay attention to the following guidelines.

- **The power cord is located at the bottom of the unit. The unit is designed to be placed on a table that will NOT pinch the power cord.**
 - Make sure the power switch is off and the unit is at room temperature before plugging in the power cord.
 - Do not block or cover any openings on the unit.
 - Do not immerse the power cord or plug in water.
 - Keep the power cord away from heated surfaces.
 - Do not allow the power cord to hang over edge of table or counter.
 - Place the unit on a sturdy, level table or other work surface.
 - Turn the power switch to off (if it is set to on).
 - Ensure the line voltage corresponds to the stated voltage on the specification label and power cord warning tag.
8. Plug the power cord into the appropriate power outlet. Refer to the specification plate for the proper voltage.

Operation

1. Press and release the Power button to turn the toaster on. Allow the toaster to warm up until **USE** appears in the display
2. Set the Compression Knobs to the desired setting. The recommended Compression Settings are: **CROWN - #4 HEEL - #3**
3. Insert product into the appropriate lane on the Bun Feeder according to Bun Feeder labels. Insert buns with the cut side facing down.
4. Finished product drops into the bun landing zone.

Light/Dark Adjustments

The light/dark value can be adjusted when the unit is displaying "USE".

1. To adjust the light/dark value, press the **LIGHTER** or **DARKER** button. The display will change to show the current light/dark value.

NOTE: The default light/dark value is d0.

2. Press the **LIGHTER** or **DARKER** buttons to change the light/dark value. The adjustment range is L1-L9 and d0-d9. L9 is the lightest, d0 is the middle, and d9 is the darkest setting.

3. To save the light/dark value, press the **PROGRAM** button or wait 5 seconds until the screen displays "USE".

NOTE: Adjusting the light/dark value does NOT change the temperature. It changes the speed of the conveyors. The light/dark value will reset to the default value of d0 when the unit is turned off.

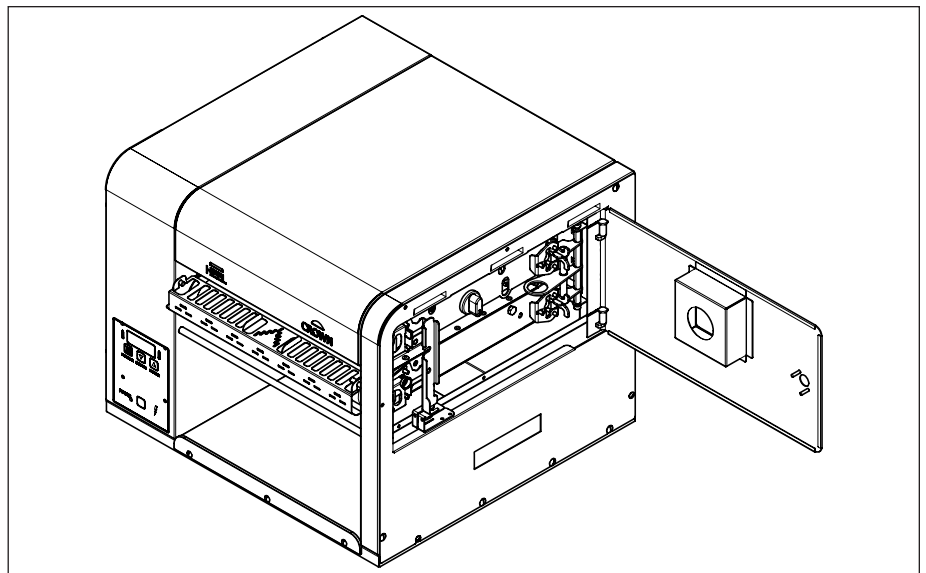

Figure 1. Gold Standard Toaster - 2H

User Mode

User Mode allows an operator to view the toaster settings but does not permit any adjustments.

1. Press and hold the **PROGRAM** button for 5 seconds. After 5 seconds, the display will show the actual temperature of the Platen.
2. Press the **LIGHTER** button to toggle between the Setpoint and actual temperature of the Platen Heater.
3. Press the **PROGRAM** button to proceed to the Motor Menu. The display shows the actual speed of the motor.
4. Press the **LIGHTER** button to toggle between the Setpoint and actual speed of the Motor.

NOTE: The unit will exit User Mode after 5 seconds of keypad inactivity.

Error Codes

If any of the following Error Codes appear, press and release the Power button to turn the toaster off. Allow the unit to cool. Then press and release the Power button to turn the toaster on. If the error repeats, contact Antunes Technical Service for assistance.

NOTE: ERR #1, 2, 3, 5, 6, 7, and 30 to 51: Internal Error. Cycle the power. If error persists, replace the board.

Error	Description
ERR 8	Motor running when it should be off.
ERR 9	High Internal Temperature.
ERR 10	Shorted Thermocouple.
ERR 11	Open Thermocouple.

Default Settings

Part #	Platen Set Point	Speed	Crown	Heel
9210961 9210962	535°F (279°C)	57	4	3
9211004	575°F (302°C)	100	4	3

Manager Mode

Manager Mode allows an operator to view and adjust the following settings:

- Heater Temperature
- Motor Speed
- Temperature Units (Celsius or Fahrenheit)

Manager Mode also allows an operator to view (but not adjust) the Ambient Temperature of the Control Compartment.

1. Press and release the Power button to turn the toaster off.
2. Press and release the Power button while holding the **PROGRAM** button. Continue holding the button until "ENA" appears on the display (after approximately 10 seconds).
3. Release the **PROGRAM** button. The display shows the Heater Setpoint Temperature.
4. To adjust the Heater Setpoint Temperature, press the **LIGHTER** or **DARKER** buttons to reach the desired temperature.

NOTE: See the Default Settings table below for recommended set point settings.

5. Press the **PROGRAM** button to proceed to the Motor Speed Setpoint.
6. Adjust the Motor Speed Setpoint by pressing the **LIGHTER** or **DARKER** buttons to reach the desired speed.

NOTE: See the Default Settings table below for recommended Speed settings.

7. Press the **PROGRAM** button to proceed to the Temperature Units.
8. To change the Temperatures units from Fahrenheit or Celsius, press the **LIGHTER** or **DARKER** buttons.
9. Press and hold the **PROGRAM** button to save any changes.

NOTE: The unit exits Manager Mode after 30 seconds of keypad inactivity.

Safety Features

Hi-Limit Control

A Hi-Limit Control turns off electrical power to the heaters and control circuits and displays HL if the unit overheats. To reset the control:

1. Let the unit cool for 15 minutes.
2. Locate the Hi-Limit Controls on the rear of the unit. Remove the black protective cap.
3. Press and release the button. Re-install the protective cap.

NOTE: If the Hi-Limit Control requires continuous resetting, contact your Authorized Service Agency.

Purging Buns from Toaster

If buns get stuck in the toaster, press and hold both the **UP** and **DOWN** arrow buttons to increase the belt speed until the buns are purged from the toaster.

Fault Messages

The unit displays fault messages when there is a problem with the unit.

- **"Hi"** flashes if the Platen Heater temperature is 30 °F more than the Setpoint or if the Platen Thermocouple is disconnected or open.
- **"CHec"** flashes when the control compartment ambient temperature is more than 150 °F (66 °C). All heaters shut off. The unit will not restart until the control compartment ambient temperature falls below 140 °F (60 °C).
- **"PO"** flashes if the incoming power drops below 190 volts. The toaster shuts down.
- **"StoP"** flashes when the motor has stopped for seven continuous seconds.
- **"SpEd"** flashes when the motor speed drops 25% below the Setpoint for 30 continuous seconds.
- **"PLt"** slow warm-up (2:20 Min)
- **"SSr"** The Solid State Relay has shorted - the unit is running beyond the setpoint temperature.

Daily Cleaning

Clean Toaster and Belt Wraps

1. Press and release the Power button to turn the unit off. The unit enters a 45 minutes cool-down mode and automatically shuts down when complete.

NOTE: The belt rollers will continue turning while in cool-down mode. This allows the entire belt to be cleaned.

2. Put on heat resistant gloves. Remove the Top Cover, Feeder, and Chute (Figure 1).
3. Wash, rinse and sanitize the Top Cover, Feeder, and Chute at the 3-compartment sink.

Inspect the belts

NOTE: Replace any belts that are torn, folded, missing snaps, or damaged. Belts should be removed ONLY during belt replacement or when required in a service situation). Refer to the section titled Replacing Belts for instructions on removing and installing belts.

1. Wipe with a clean, sanitized towel and allow to air dry.
2. Clean the top and bottom belts.

NOTE: Repeat as needed to remove heavy carbon buildup. Be sure to sanitize the belts completely. Failure to properly clean the belts will shorten the life of the belts and result in poor performance.

3. Wipe the exterior surfaces of the unit with a clean, sanitizer-soaked towel and allow to air dry.
4. Reinstall all accessories (Figure 1).
5. Turn on the unit on and test the unit before returning it to operation.



Examples of damaged belts



Replace belts that are wrinkled or distressed around snaps or with snaps that are loose, damaged, or missing.



Replace torn or folded belts



Replace the belt if snaps are missing or damaged.

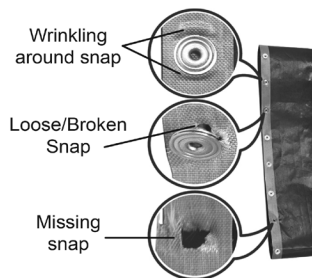

Quarterly Cleaning

Remove Belt Wraps and Clean Rollers

1. Turn the toaster's power switch to the off position. The toaster enters a cool-down mode and will automatically shut down when complete.
2. Unplug the power cord once the cool-down period is complete.

NOTE: Wait for the cool-down period to complete before unplugging the power cord.

3. Remove the bun feeder using heat-resistant gloves.

NOTE: Reposition the toaster as needed to perform these steps.

4. Unlock the lock on the right side panel with a flathead screwdriver and open the panel. Turn the compression knobs (there are 2) to 7.

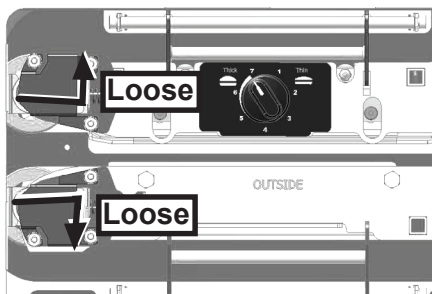
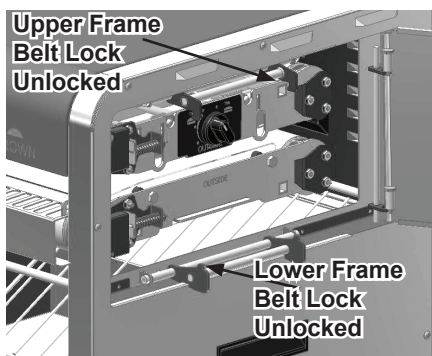

Figure 2. Loosening the conveyor rollers

5. Remove tension on the Top Belt by pushing the Top FRONT Roller IN and UP until it locks into position.
6. Remove tension on the Bottom Belt by pushing the Bottom FRONT Roller IN and DOWN.
7. Unlock the Top and bottom lock levers. (See below).



- Figure 3. Conveyor locks
8. Carefully remove the two top belts and one bottom belt.

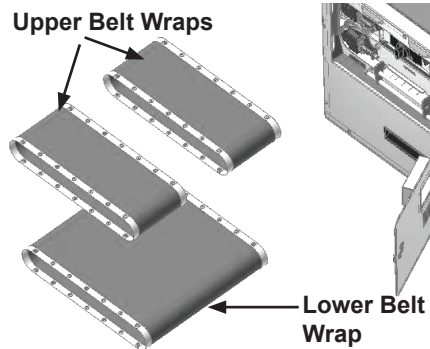

Figure 4. Belt Wraps

9. Wipe all four rollers and backing plates with a clean, damp sanitized towel. Make sure to remove all debris from the rollers and the backing plates so they are as clean as possible.
10. Use a dry cloth towel or nylon-bristled brush to remove all debris from both side compartments, inside of the toaster, and underneath the rollers.

Install Belt Wraps

1. If you are installing the existing belt wraps, inspect the belts. Replace belt wraps if worn or damaged. If the belt wraps are in good condition put them back on the toaster.
2. For new or existing belts, wipe both sides of the belts with a clean, damp sanitized towel. Allow to air dry.
3. Slide the belts gently over the appropriate top and bottom roller. Make sure the belt lines up properly on the rollers. The belts should face the inside of the roller.
4. Restore tension on the bottom belt by pushing UP and OUT (See figure 5).
5. Restore the tension on the top belt by pushing DOWN and OUT (See figure 5).

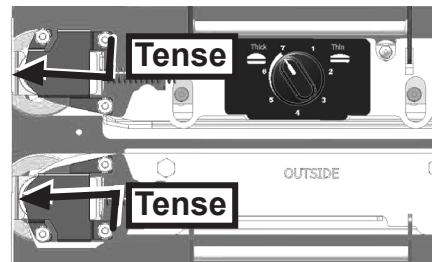

Figure 5. Conveyor rollers under tension

NOTE: Lift up on the camshaft of the rear conveyor roller while lifting the conveyor lock.

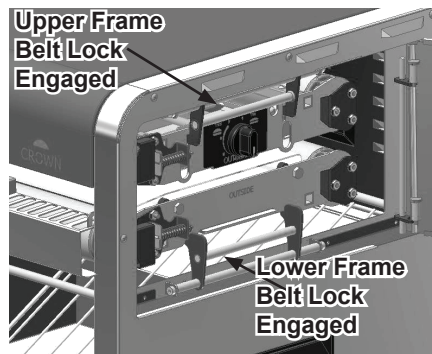

Figure 6. Belt frame locks

6. Engage the top and bottom lock levers as shown above. Make sure the lock lever is properly inserted into the slotted grooves.
7. Close the side panel and lock the lock using a flathead screwdriver on the side panel.
8. Set the Crown compression knob to 4 and the Heel to 3.
9. Re install the top cover and bun feeder onto the unit.
10. Plug in the power cord and turn the unit on.

Annual Cleaning

Clean Cooling Fans and Electrical Housings

1. Turn the toaster's power switch to the off position. The toaster enters a cool-down mode and will automatically shut down when complete. Unplug the power cord.
2. Remove the push knob and top six screws on the left side of the toaster and set aside.
3. Using the handle, remove the left side cover of the unit by lifting up and away from the unit (See Figure 7). Set aside.
4. Remove any debris or dust from the cooling fan with a small brush. Wipe away any debris with a clean, dry towel. Inspect the electrical compartment for crumbs and debris. Clean out all crumbs and debris using a clean, dry towel or nylon bristled brush. Be careful not to disrupt any of the electrical wiring.
5. Replace the left side panel cover by sliding it onto the bottom screws.
6. Reconnect with the screws and replace Push on Knob.

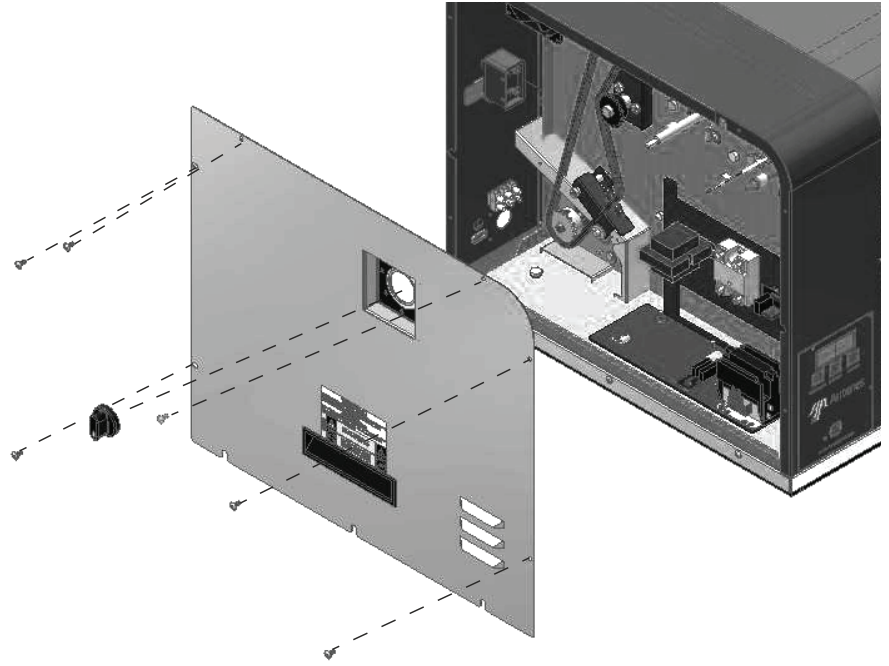

Figure 7. Accessing the cooling fan

Troubleshooting

Problem	Possible Cause	Corrective Action
Control Display flashes PLt continuously. Buns not toasting properly.	Platen temperature is below 575 °F (302 °C).	Allow the unit to warm up for 30 minutes and then recheck. If the Control Display still flashes PLt , contact your maintenance person or Antunes Technical Service for service.
	Failed Platen Thermocouple.	Contact your maintenance person or Antunes Technical Service for service.
	Failed Control Board	
Control Display flashes Er 9 continuously.	Control Compartment ambient temperature is above 150 °F (66 °C)	Verify side vents on toaster are unblocked and not near other heating appliances. If problem persists contact your maintenance person or Antunes Technical Service for service.
	Failed Cooling Fan.	
	Failed Control Board	
Control Display Flashes SSr continuously. Buns Burn.	Failed Front Platen Solid State Relay.	Contact your maintenance person or Authorized Service Agency for service.
	Failed Control Board.	
	Failed Front Platen Thermocouple.	
Control Display flashes Er 11 continuously. Buns not toasting properly.	Loose Platen Thermocouple connection on Control Board or the Platen Thermocouple is open.	Re-secure the Platen Thermocouple to the Control Board. If the Control Display still reads Er 11 , check the Thermocouple for continuity. Contact your maintenance person or Antunes Technical Service for service.
	Failed Control Board.	
Control Display flashes Er 10 continuously. Buns not toasting properly.	Shorted Platen Thermocouple to ground.	Disconnect and re-secure the Platen Thermocouple connection to the Control Board. If the Control Display still reads Er 10 , check the Thermocouple for continuity. Contact your maintenance person or Antunes Technical Service for service.
	Failed Control Board	
Control Display flashes StoP .	Mechanical bind in one or both conveyors.	Enter "user mode" to check the motor speed. Check both conveyors for mechanical binds. Test the motor. Replace necessary parts. Contact your maintenance person or Antunes Technical Service for service.
	Worn or damaged Ball Bearings.	
	Drive chain or sprockets damaged.	
	Failed Motor.	
	Failed Control Board.	
Control Display flashes SpEd .	Mechanical bind in one or both conveyors.	Enter "user mode" to check motor speed. Check both conveyors for mechanical binds. Replace necessary parts. Contact your maintenance person or Authorized Service Agency for service.
	Worn or damaged Ball Bearings.	
	Conveyor chains loose or damaged.	
	Drive chain or sprockets damaged.	
Crowns and/or Heels must be forced into the toaster. Buns sticking and burning.	Belts are dirty, worn, or damaged (replace every 2-4 months).	Clean or replace Belts as described in the Maintenance section of this manual.
	Buns do not meet specifications.	Contact your bun supplier.
Buns not toasting adequately.	Compression Setting is incorrect.	Use the recommended setting of 4 for Crowns and 3 for Heels.
	One of the Conveyor shafts is stuck in the lower lock position.	Inspect positions of the shafts as described in the Maintenance section of this manual.
	Either both Upper/Lower Conveyor locks are not properly locked in place.	Inspect the proper position of the locks as described in the Maintenance section of this manual.
	Buns do not meet specifications.	Contact your bun supplier.
	Motor settings are incorrect.	Verify that the motor setting is set to 4000 as described in the Programming section of this Manual.
Compression side door will not close.	Either both Upper/Lower Conveyor Locks are not properly locked in place.	Inspect the proper position of the locks as described in the Maintenance section of this manual.
	The lock on the Compression Side Door is in the locked position when trying to close the door.	Turn the lock to the unlocked position before closing the door.

Problem	Possible Cause	Corrective Action
Fan is making an unusual sound.	Failed Cooling Fan.	Verify vents on toaster are unblocked and not near other heating appliances. Clean fans as described in the Maintenance section of this manual. If problem persists, contact your maintenance person or Antunes Technical Service for service.
	Cooling Fan is dirty and needs to be cleaned.	
Control Display flashes HL continuously. Buns are not toasting properly.	Hi-Limit Control is tripped.	Allow the unit to cool and reset the Hi-Limit Control. If it trips again, contact your maintenance person or Antunes Technical Service for service.
Control Display is blank.	Power Cord is not plugged in.	Plug the Power Cord into the appropriate outlet. Turn the toaster on. If the Control Display is still blank, contact your maintenance person or Antunes Technical Service for service.
	Circuit Breakers turned off or tripped. Damaged electrical outlet, plug, or Power Cord. Power Switch damaged.	Reset Circuit Breakers. If they trip again, check the Power Cord, Plug, and outlet for damage. Contact your maintenance person or Antunes Technical Service for service.
	Faulty Transformer.	Replace Transformer.
Conveyors not turning.	Belt is damaged.	Replace Belts
	Motor Drive Chain is detached from sprockets.	Reinstall the Drive Chain.
	Failed Drive Motor.	Contact your maintenance person or Antunes Technical Service for service.
Belts are ripped or torn.	Rollers or Heater Cover Plates are dirty and need to be cleaned.	Clean Rollers and Heater Cover Plates as outlined in the Maintenance section of this manual.
	Belts are not installed properly.	Install Belts correctly as outlined in the Maintenance section of this manual.
	Roller(s) in the incorrect locked position during operation.	Unlock Rollers to operational position.
	Front Conveyor Lock is disengaged.	Engage and lock the Front Conveyor Lock.

Exploded Diagram 1

NOTE: Use only genuine Antunes replacement parts in this unit. Use of parts other than those supplied by the manufacturer will void the warranty.

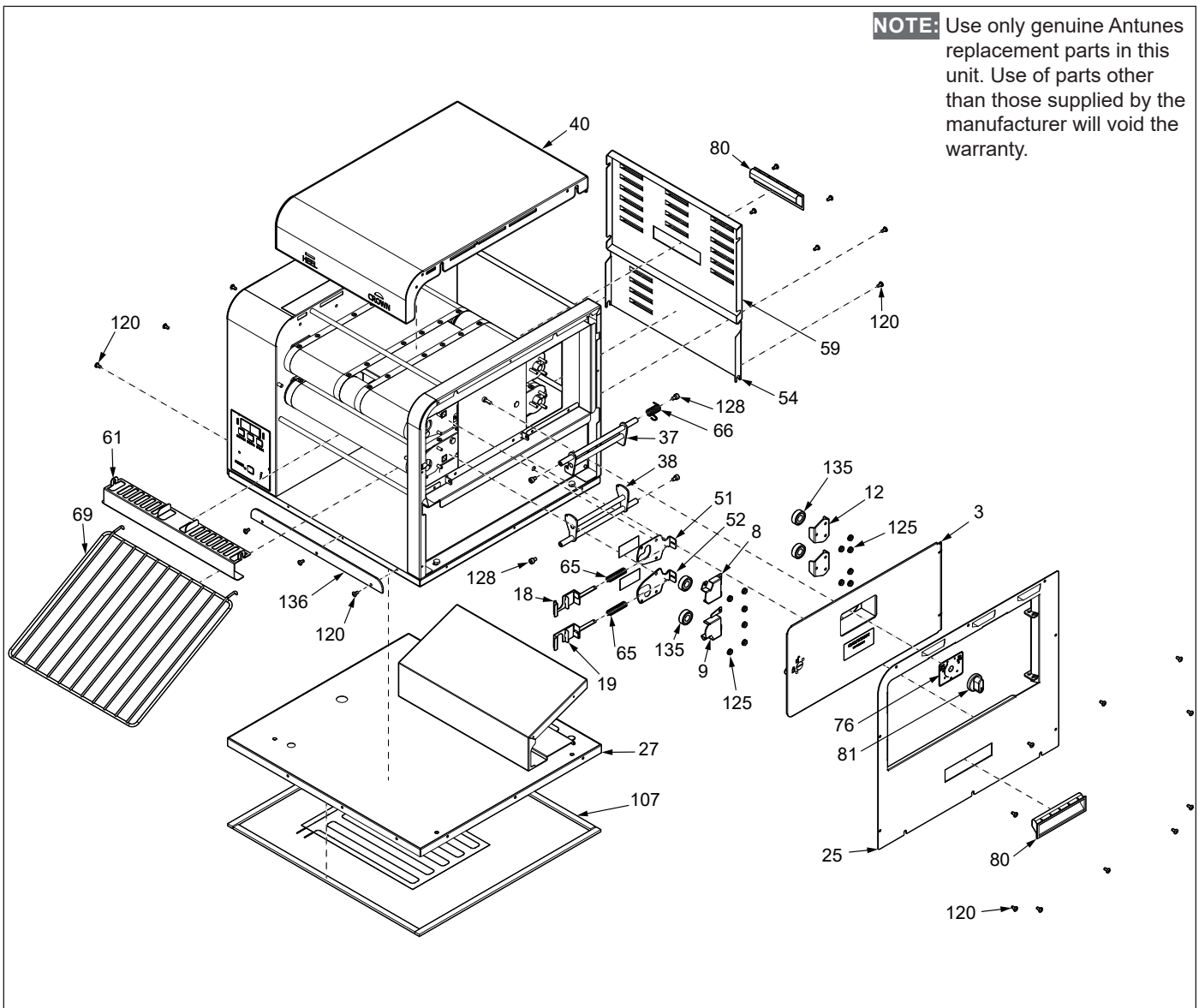

Exploded Diagram 2

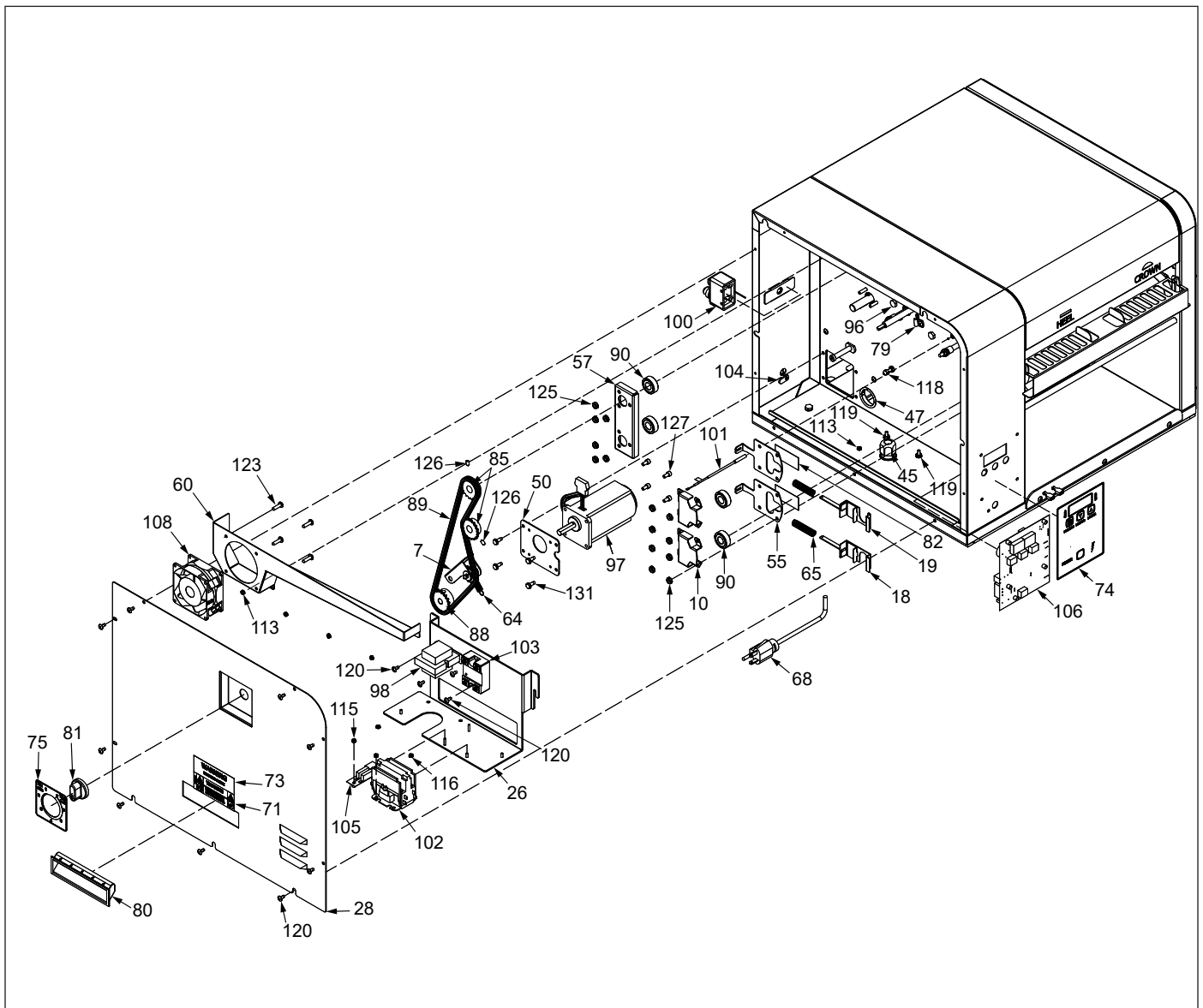

NOTE: Use only genuine Antunes replacement parts in this unit. Use of parts other than those supplied by the manufacturer will void the warranty.

Exploded Diagram 3

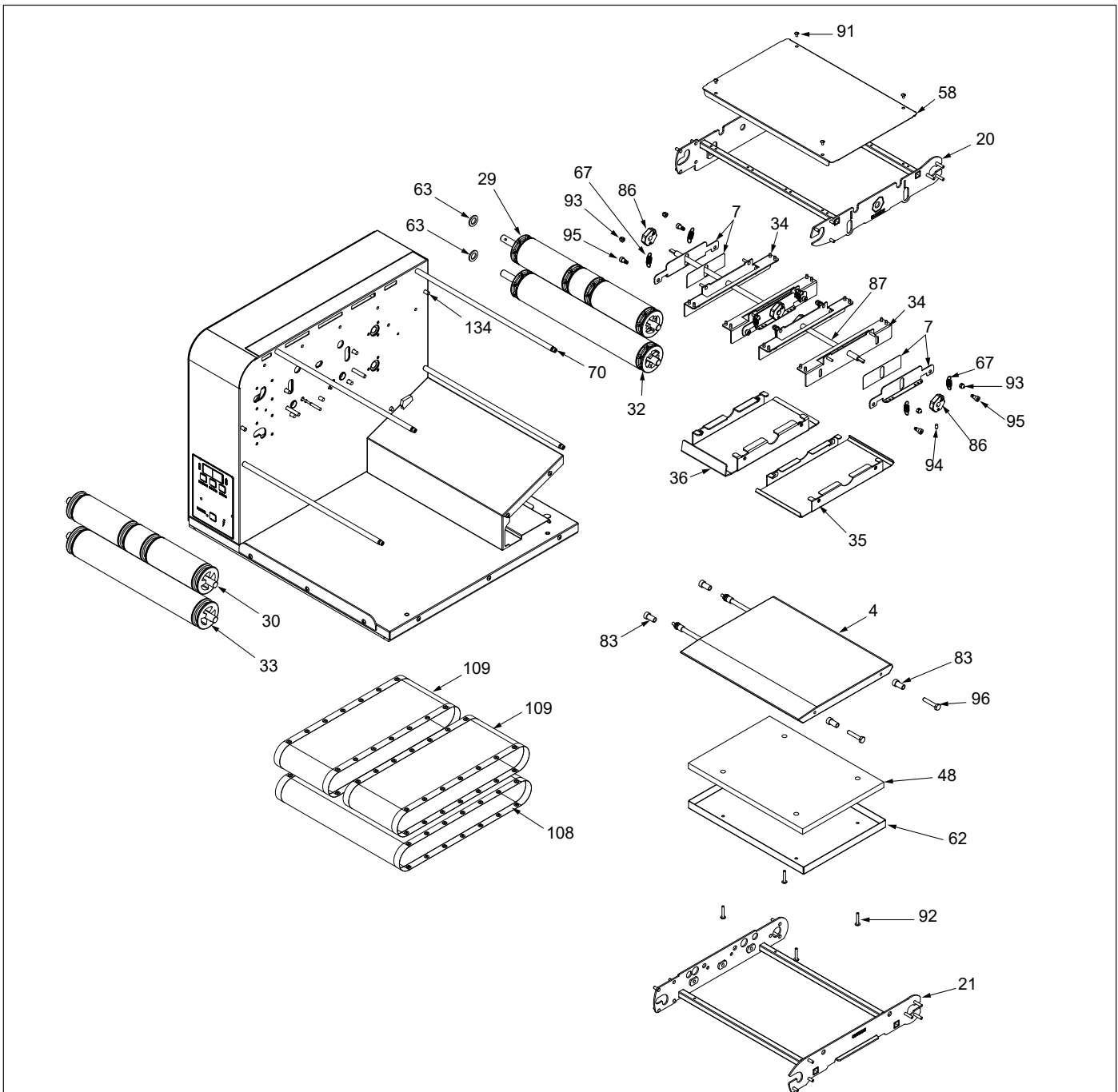

NOTE: See Next Page for Parts List related to this graphic.

NOTE: Use only genuine Antunes replacement parts in this unit. Use of parts other than those supplied by the manufacturer will void the warranty.

Replacement Parts

Item No.	Part #	Description	Qty.
2	0012913	Insulator Assembly	1
3	0012961	Door Assembly	1
4	0013024	Platen Assembly (Mfg. No. 9210962 & 9211004)	1
	0013234	Platen Assembly (Mfg. No. 9210961)	1
6	0013025	Drive Motor Assy	1
7	0013092	Cam Bracket Assy	4
8	0013093	Brkt Assy Top	1
9	0013094	Brkt Assy Bottom	1
10	0013095	Bearing Brkt Assy	2
11	0013096	Adjustable Frame Assy	1
12	0013104	Brg Cover Assy.	2
13	0013109	Duct Assembly	1
14	0013110	Housing Door Assy (Mfg. No. 9210961)	1
15	0013111	Assy, Drive Chain Tensioner	1
16	0013234	Platen Assembly (Mfg. No. 9210961)	1
17	0013249	Housing Door Assy (Mfg. No. 9210962)	1
18	0021724	Weldment, Brg. Brkt. & Spring Guide RH	2
19	0021725	Weldment, Brng Brkt & Spring Guide LH	2
20	0021864	Adjust Frame Wldmt	1
21	0021865	Main Platen Frame Wldmt	1
22	0021885	End Housing Weldment	1
23	0021894	Weldment, End Cover Lock	1
25	0021897	End Housing Panel Weldment	1
26	0021916	Ele. Bracket Weldment	1
27	0021940	Base Weldment	1
28	0021950	Panel Weldment Control Hsgn.	1
29	0021953	Weldment, Drive Roller Adj. Lanes	1
30	0021954	Weldment, Idler Adjust Lanes	1
32	0021976	Wldmnt, Drive Roller Main Platen	1
33	0021977	Weldment, Idler, Roller Main Platen	1
34	0022004	Slide Plate Wldmt	4
35	0022005	Crown Plate Wldmt	1
36	0022006	Heel Plate Wldmt	1
37	0022007	Top Hinge Lock Wldmnt	1
38	0022008	Bottom Hinge Lock Wldmnt	1
40	0022105	Cover Weldment	1
41	0022245	Plate Wldmt Line Filter (Mfg. No. 9210961 only)	1
44	0400119	Busing, Shorty 5/8" (Mfg. No. 9210961 & 9210004 only)	3
45	0400251	Strain Relief Cord Connector	1
47	0400432	Bushing, Open/Closed	1
48	0400458	Insulation, Main Platen	1
50	0506157	Motor Plate	1
51	0506543	Plate, Tensioner LH	1
52	0506544	Plate, Tensioner RH	1
54	0506562	Electrical Cover	1
55	0506566	Plate, Tensioner	2
57	0506839	Bearing Retainer Brckt.	1
58	0506853	Frame Cover	1
59	0506860	Back Cover	1
60	0506862	Duct	1

Item No.	Part #	Description	Qty.
61	0506864	Bun Ramp	1
62	0507092	Insulation Plate	1
63	0507140	Alum Washer	2
64	0600143	Spring, Compression Setting	1
65	0600158	Spring, Roller Tension	4
66	0600161	Torsion Spring, Locking Bracket Top	1
67	0600162	Spring, Cam	8
68	0700453	Power Cord CEE 7/7, 16 Amp., 250 VAC (Mfg. No. 9210961)	1
	0700932	NEMA 6-20P 20 Amp, 250 Volt Right Angle (Mfg. No. 9210962)	1
	0701120	Power Cord Plug, Locking L6-15P (Mfg. No. 9211004)	1
69	0800467	Bun Chute (Mfg. No. 9210961 & 9210962 ONLY)	1
70	0800473	Rod, Hsg. Spacer 14.375 LG	4
71	1000900	Label, Warning	1
72	1001192	Label, Caution Hot	1
73	1001213	Label, Shock Hazard	1
74	1001505	Label, Control	1
75	1001585	Label, Compression LH	1
76	1001586	Label, Compression RH	1
77	1001589	Label, Wiring Diagram (Mfg. No. 9210962 & 9211004)	1
78	1001643	Label, Wiring Diagram (Mfg. No. 9210961)	1
79	2110197	Clip, Steel Cable	1
80	2100212	Handle, Pocket Pull Snap In	2
81	2100253	Knob, 1/4" Shaft, Push on	2
82	2100334	Thrust Strip	4
83	2120233	Spacer .252 ID X .5 OD X .935" LG	4
85	2150185	Sprocket, 25B18, 1/2" Bore	2
86	2150362	Cam, Hbcs	4
87	2150376	Shaft Crown	1
88	2150378	Sprocket, 25B20 3/8" Bore	1
89	2150393	Drive Chain	1
90	2150484	Bearing ASsy, Hi-Temp 1 1/8" OD X 1/2: ID	8
91	3080144	Screw, #8-32 X 1/4" (#6 Head)	4
92	3080164	Screw, Mach. #8-32 X 1"	4
93	3080340	Nut, Hex Acorn Lock #8-32	8
94	3100187	Screw Set, #10-32 X 3/8 Hex Socket-Cone Point	4
95	3100215	Scr, Shldr #10-32 X 1/4" W/ 1/4" Shldr Precision	8
96	3250193	Screw, Hex Head, #1/4-20 X 1.375", S.s.	4
97	4000186	Motor, 230 V	1
98	4010187	Transformer 240 VAC 12 VAC	1
99	4010221	CAP MP Motor Run	1
100	4030352	Thermostat, HiLimit 700	1
101	4050214	Thermocouple Type K Open End	1
102	4050236	Contact, 2 Pole	1
103	4051010	Relay, Random Phase Solid State 50A	1
104	4060374	Ground Lug	1
105	4070154	Varistor Board	1
106	4070415	Assy-PCB GST-2H KFC	1

Replacement Parts

Item No.	Part #	Description	Qty.
107	0200343	Gasket 20"	4
108	7000913	Replacement Fan Kit	1
109	7000984	Main Belt	1
110	7000991	Crown & Heel Belt	1
112	7001428	Line Filter 10 A (Mfg. No. 9210961 only)	1
113	206P130*	Nut, HEX KEPS #6-32 (Small Pptrn)	1
115	304P105*	Nut, Hex KEPS #4-40	1
116	306P130*	Nut, Hex Keps #6-32 (Small Pattern)	9
117	308P124*	Screw, Mach One Way #8-32	1
118	308P145*	Nut, HEX Acorn #08-32 Low Crown	1
119	308P199*	Nut, HEX KEPS #8-32	1
120	308P203*	Screw, Tap 8-32 X 3/8" W IntTooth Wshr	1
123	308P340*	Nut, HEX Acorn Lock #8-32	1
124	310P102*	Washer, IntTooth Lock #10	1
125	310P146*	Nut, Hex KEPS #10-32	1
126	310P187*	Screw Set, #10-32 x 3/8 HEX, Socket-Cone Point	2
127	3100188	Socket Head Cap Screw	4
128	310P196*	Screw, Shoulder 10-32 SS	1
129	310P204*	Fillister Head Phillips Screw #10-32 x .25	1
130	310P213*	Screw, PHPNHD #10-16 X 3/4" THRD Form	1
131	310P214*	Screw, HEX #10-32 x 1/2"	1
132	325P154*	Washer 1/4" Helical Spring Lock	1
133	325P177*	Screw, Shoulder 5/16 SD	1
134	325P192*	Screw, HEX head #1/4-20 x 1.275" SS	1
135	2150384	Bearing Assy, Hi-Temp 1 1/8" Od X 1/2" Id	8
136	0506835	Bun Stop (Mfg. No. 9210961 & 9210962 ONLY)	1
137	0325109	Screw ,Hexcap 1/4-20 X 1/2 S.s. T304; Brt	9
138	7001054	GST-2H Belt Kit	1

Wiring Diagram Mfg No. 9210961

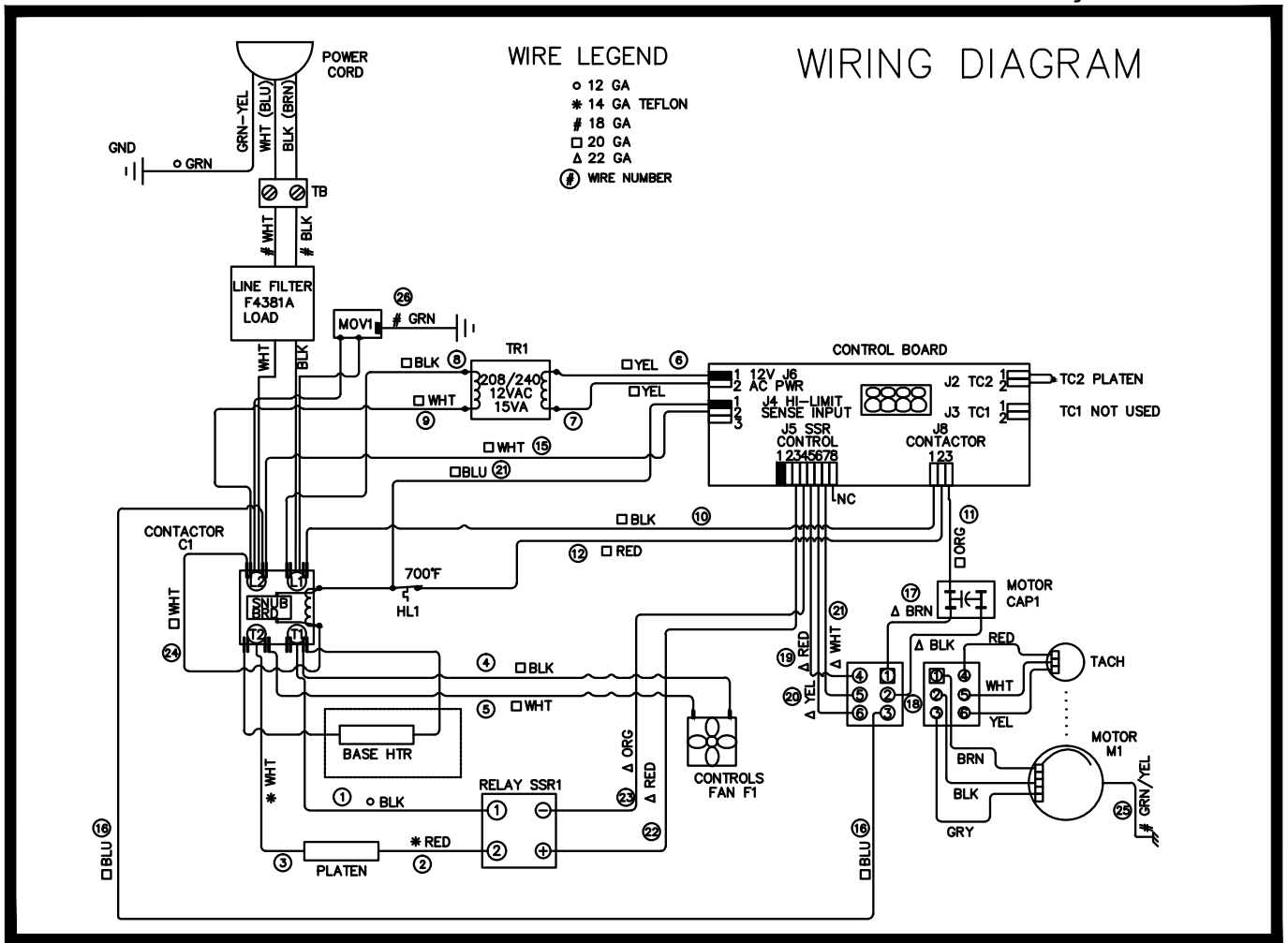

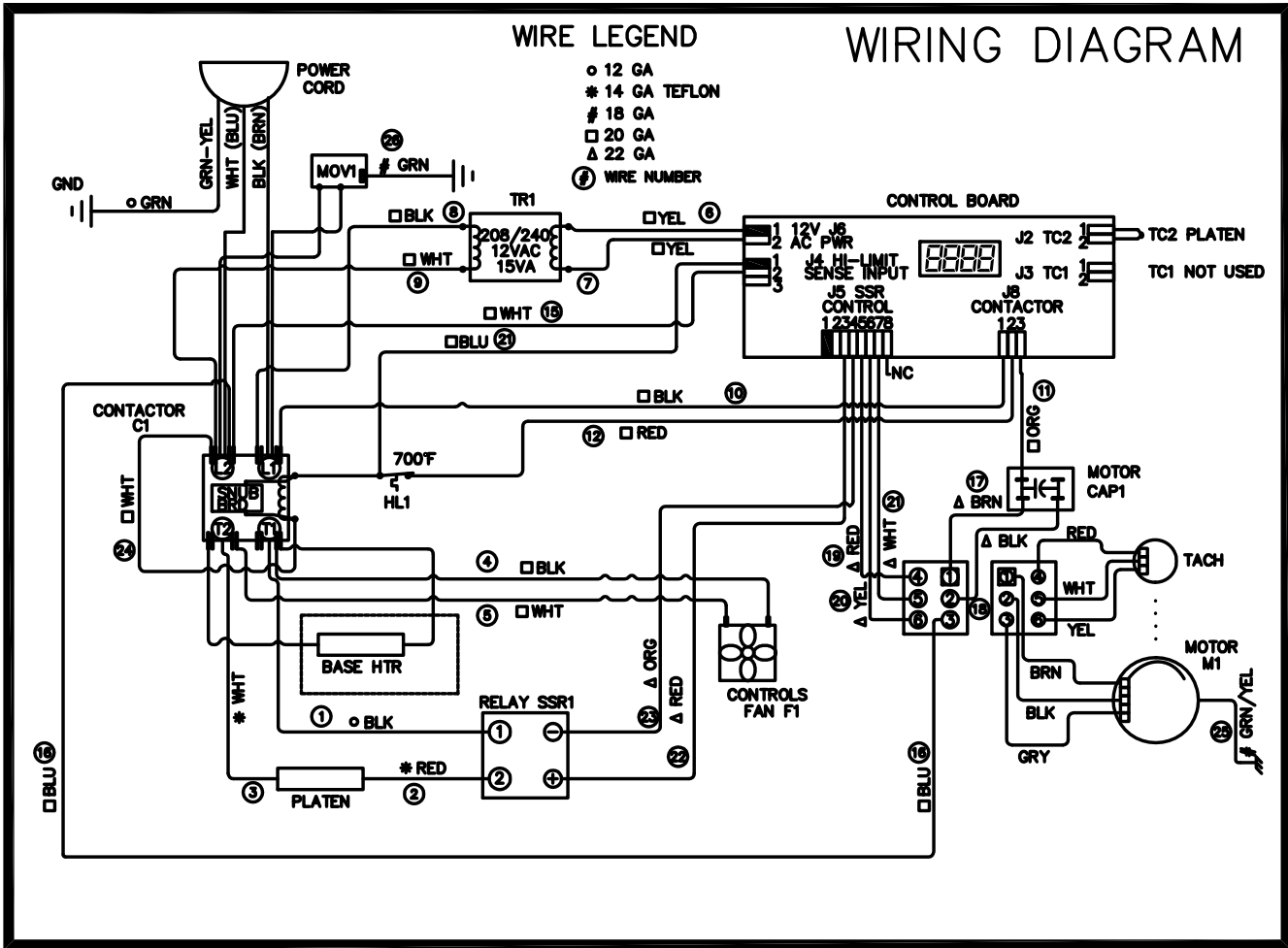

Limited Warranty

Equipment manufactured by Antunes has been constructed of the finest materials available and manufactured to high quality standards. These units are warranted to be free from electrical and mechanical defects for a period of eighteen (18) month from date of purchase under normal use and service, and when installed in accordance with manufacturer's recommendations. To insure continued operation of the units, follow the maintenance procedures outlined in the Owner's Manual. During the first 18 months, electro-mechanical parts, non-overtime labor, and travel expenses up to 2 hours (100 miles/160 km), round trip from the nearest Authorized Service Center are covered.

This warranty does not cover cost of installation, defects caused by improper storage or handling prior to placing of the Equipment. This warranty does not cover overtime charges or work done by unauthorized service agencies or personnel. This warranty does not cover normal maintenance, calibration, or regular adjustments as specified in operating and maintenance instructions of this manual, and/or labor involved in moving adjacent objects to gain access to the equipment. This warranty does not cover consumable/wear items. This warranty does not cover damage to the Load Cell or Load Cell Assembly due to abuse, misuse, dropping of unit/shock loads or exceeding maximum weight capacity (4 lbs). This warranty does not cover water contamination problems such as foreign material in water lines or inside solenoid valves. It does not cover water pressure problems or failures resulting from improper/incorrect voltage supply. This warranty does not cover Travel Time & Mileage in excess of 2 hours (100 miles/160 km) round trip from the nearest authorized service agency.

Antunes reserves the right to make changes in design or add any improvements on any product. The right is always reserved to modify equipment because of factors beyond our control and government regulations. Changes to update equipment do not constitute a warranty charge.

If shipment is damaged in transit, the purchaser should make a claim directly upon the carrier. Careful inspection should be made of the shipment as soon as it arrives and visible damage should be noted upon the carrier's receipt. Damage should be reported to the carrier. This damage is not covered under this warranty.

Warranty charges do not include freight or foreign, excise, municipal or other sales or use taxes. All such freight and taxes are the responsibility of the purchaser.

This warranty is exclusive and is in lieu of all other warranties, expressed or implied, including any implied warranty or merchantability or fitness for a particular purpose, each of which is hereby expressly disclaimed. The remedies described above are exclusive and in no event shall ANTUNES be liable for special consequential or incidental damages for the breach or delay in performance of this warranty.

The warranty does not extend to:

- Damages caused in shipment or damage as result of improper use.
- Installation of electrical service.
- Installation, calibration, or adjustment.
- Normal maintenance outlined in this manual.
- Malfunction resulting from improper service or maintenance.
- Damage caused by improper installation, abuse, or careless handling.
- Damage from moisture getting into electrical components.
- Damage from tampering with, removal of, or changing any preset control or safety device.
- Damage caused by parts or components not provided by Antunes



Corporate Headquarters
Carol Stream, IL, USA
Phone: +1.630.784.1000
Toll Free: +1.800.253.2991
Fax: + 1.(630).784-1650

China Facility
Suzhou, China
Phone: +84.512.6841.3637
Fax: +86.512.6841.3907

India Facility
Chennai, India
Phone: +91.44.25532212
Fax: +91.44.25532415